

ADJUSTABLE FIXTURE SUPPORTS
FOR ELEVATED SIPHON JET WATER CLOSETS FOR WHEELCHAIR USERS DEEP ROUGH-IN TYPE

HORIZONTAL FITTINGS

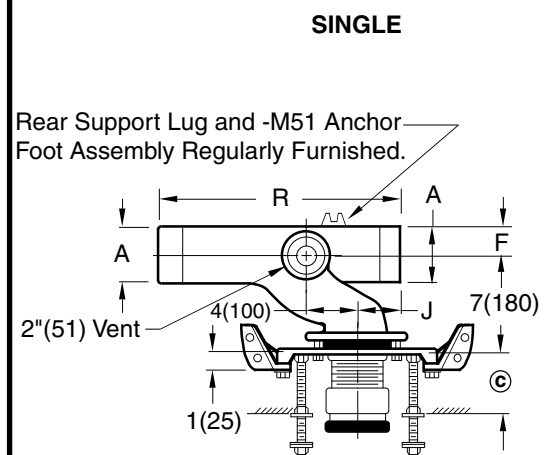

Rear Support Lug and -M51 Anchor Foot Assembly Regularly Furnished.

**Fig. 0115RY
Top View**

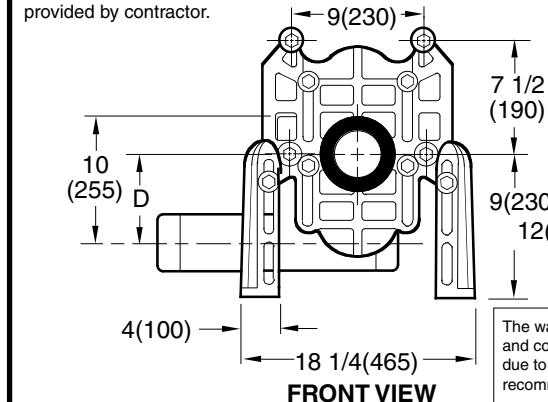

FRONT VIEW

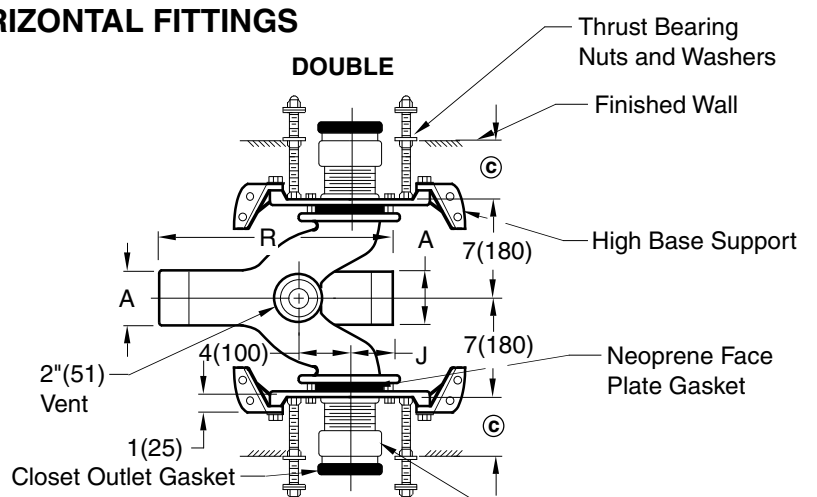

**Fig. 0115DY
Top View**

- Fig. 0115LY ... NO-HUB Left Hand
- Fig. 0115RY ... NO-HUB Right Hand
- Fig. 0115DY ... NO-HUB Double

A SIZE	D		J	R	F
	MIN	MAX			
4(100)	4 5/8(117)	8 5/8(219)	4(100)	14(355)	2 1/4(57)

The water closet gasket regularly furnished is made of molded neoprene and designed to fit water closet outlet dimensions and configurations shown in ANSI Standard A112.19.2M-1995, Figure 13B. If gasket is not found to be compatible to fixture due to nonconformance of said fixture to ANSI A112.19.2M, then fixture manufacturer shall be consulted for a suitable gasket recommendation. Jay R. Smith assumes no liability for connections to fixtures which do not conform to these standards.

**© DIMENSION - ADJUS-TO-WALL
TYPE OUTLET CONNECTION**

The Smith Adjus-to-Wall outlet connection provides adjustment at the face of the wall at the time the fixture is set; thus, compensating for wall construction variations. The © dimension is measured from the front of the face plate to the finished wall. To properly determine the length of nipple required, deduct 1" (25) from the © dimension. The Adjus-to-Wall coupling will provide 1/2" (13) horizontal adjustment in either direction with the coupling extended 5/16" (8) past face of the finished wall.

© dimension = 4" (100) (regularly furnished) consisting of nipple and Adjus-to-Wall coupling permitting adjustment from 3" (76) min. to 4" (100) max.

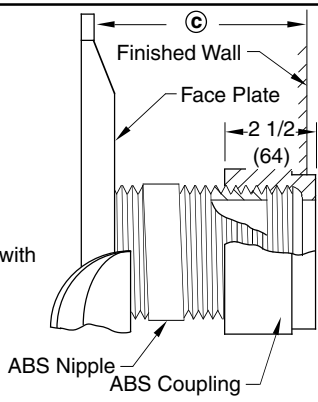

NIPPLE LENGTHS AVAILABLE

LENGTH	MIN.	©	MAX.
2 1/2(64)	2 1/4(57)		3 1/4(83)
*3 1/4(83)		3(76)	4(100)
*8 1/4(210)	8(205)		9(230)
10(255)	9 3/4(250)		10 3/4(275)
12(305)	11 3/4(300)		12 3/4(325)
15(380)	14 3/4(375)		15 3/4(400)
18(455)	17 3/4(450)		18 3/4(475)

NOTE: Dimensions shown in parentheses are in millimeters.

*ABS (Regularly Furnished) other lengths PVC.

NOTE: When nipple lengths between 3 1/4" (83) and 8 1/4" (210) are specified, the 8 1/4" (210) nipple will be supplied. Nipple must be cut to specified length by others.

DRAWING NUMBER S0115Y
 SIZE A
 SCALE: NONE
 DATE: 1-3-85
 APPROVED BY: JD
 CHECKED BY: VGD
 DRAWN BY: CM
0115Y
 DIMENSIONS ARE SUBJECT TO MANUFACTURERS TOLERANCE AND CHANGE WITHOUT NOTICE

REV.	DATE	DESCRIPTION	BY	CKD. BY
K	6-30-98	Submittal Update	ASL	BS
J	1-22-98	Changed Callout & 4 was 04	EMB	BS
H	3-3-97	Added Millimeters	EMB	BS
G	6-21-94	Revision	EMB	BS
F	7-7-93	Submittal Update	EMB	BS

WEIGHT POUNDS	VOLUME CUBIC FEET	FIGURE NUMBER
		0115Y

MODIFICATIONS & VARIATIONS FOR SIPHON JET WATER CLOSETS

RECOMMENDED SETTING OF CLOSET OUTLET CONNECTION AND FIXTURE STUDS

Manufacturers have slight differences in the depth of the closet horn and flange thickness of their closets. Usually the fixture support closet connection should extend 5/16" (8) beyond face of finished wall (Dimension "R") and the fixture studs 2 1/4" (57) (Dimension "X"). For exact dimensions please use the formulas below.

DETAIL A Formula for "R" is: $S + 1/16" (2) - D = R$.
 S = Depth of closet horn
 1/16" (2) = Distance closet is to set away from finished wall.
 D = 1/2" (13) for felt gasket and 3/8" (10) for neoprene gasket.
 R = Distance coupling should extend beyond finished wall.
NOTE: When the fixture is installed, closet gasket must be compressed sufficiently to assure a gas and water-tight seal.

DETAIL B Formula for "X" is: $Y + 1/16" (2) + 9/16" (14) = X$.
 Y = Thickness of closet wall flange.
 1/16" (2) = Distance closet is to set away from finished wall.
 X = Distance supporting stud should extend beyond finished wall.
NOTE: Bearing nuts and washers must be set to take full loading from the fixture allowing 1/16" (2) clearance between fixture and wall.

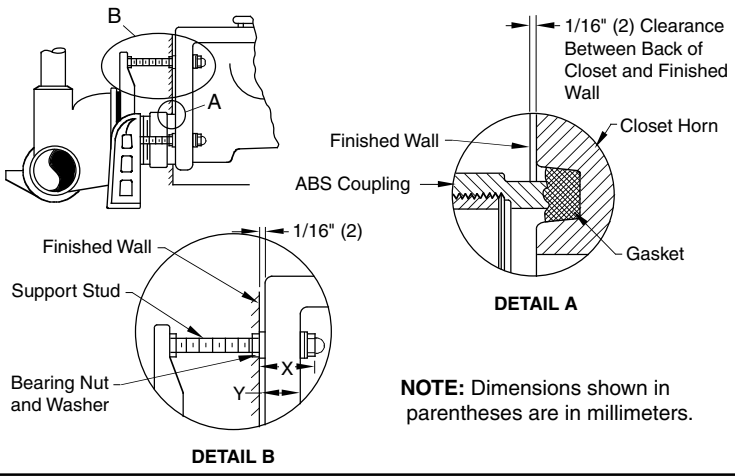

NOTE: Dimensions shown in parentheses are in millimeters.

OPTIONAL CLOSET OUTLET CONNECTIONS

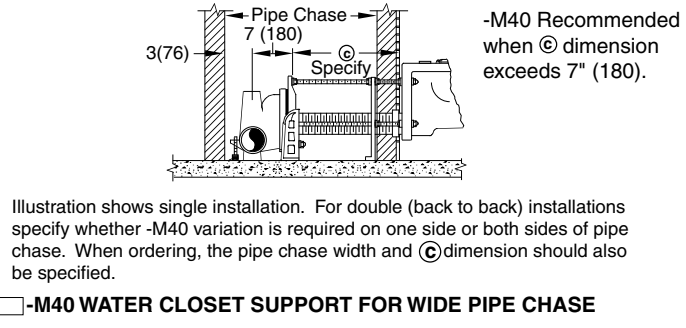
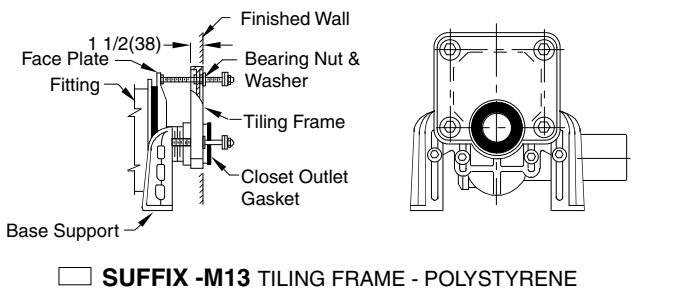
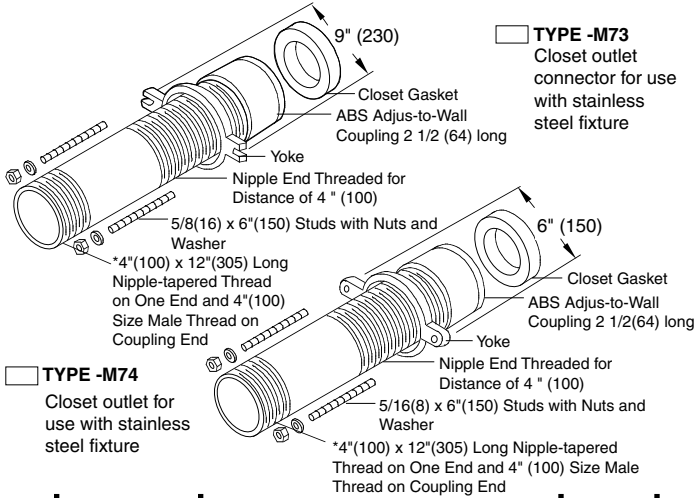
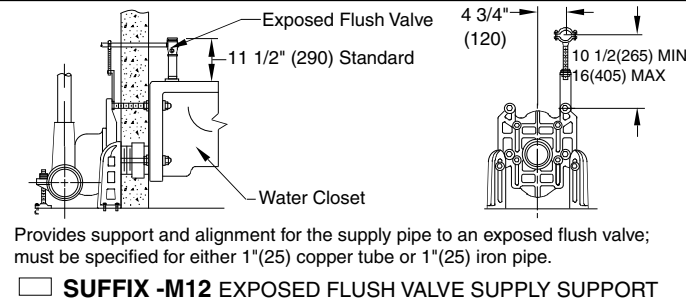
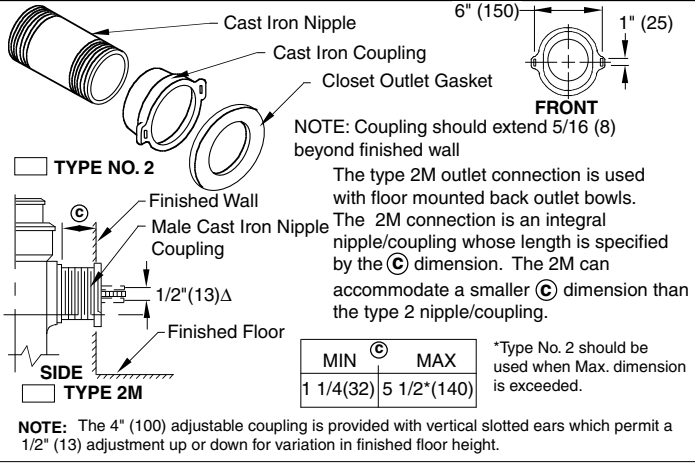

DRAWING NUMBER: S0100BS
 SIZE: A
 SCALE: NONE
 DATE: 1-16-85
 APPROVED BY: JD
 CHECKED BY: CR
 DRAWN BY: VGD
 100/400 Series Back Sheet
 DIMENSIONS ARE SUBJECT TO MANUFACTURERS TOLERANCE AND CHANGE WITHOUT NOTICE
 WE CAN ASSUME NO RESPONSIBILITY FOR USE OF SUPERSEDED OR VOID DATA

REV.	DATE	DESCRIPTION	BY	CKD. BY
C	12-10-03	Added Note	RN	CL
B	2-26-96	Added Millimeters	EMB	BS
A	7-1-93	Submittal Update	EMB	BS

WEIGHT POUNDS	VOLUME CUBIC FEET	FIGURE NUMBER 100/400 Series Back Sheet
---------------	-------------------	--