



JAY R. SMITH MFG. CO.
 DIVISION OF SMITH INDUSTRIES, INC.
 POST OFFICE BOX 3237
 MONTGOMERY, ALABAMA 36109-0237 (USA)
 TEL: 334-277-8520 FAX: 334-272-7396 www.jrsmith.com



LOCATION

ADJUSTABLE FIXTURE SUPPORTS FOR SIPHON JET WATER CLOSETS

NO-HUB HORIZONTAL FITTINGS EXTRA HEAVY DUTY - 750 LBS.

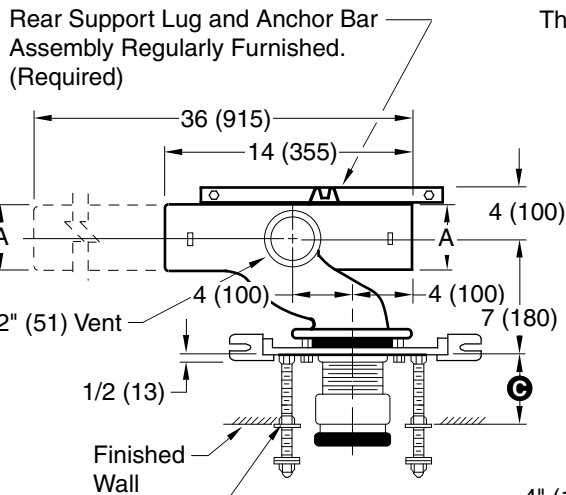

Top View SINGLE

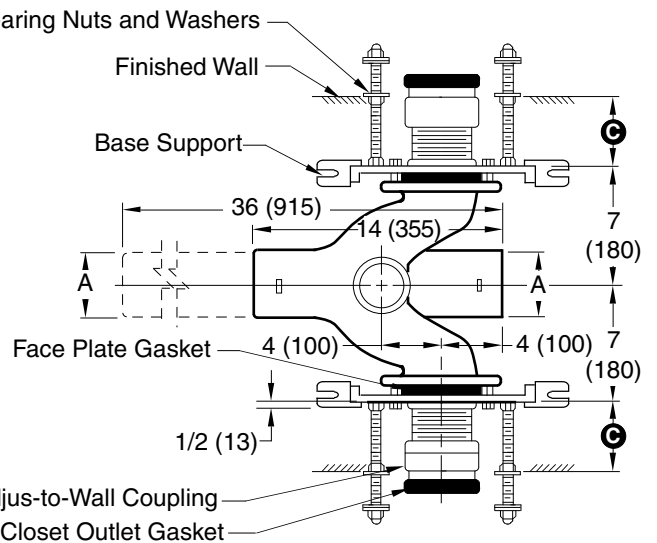

Top View DOUBLE

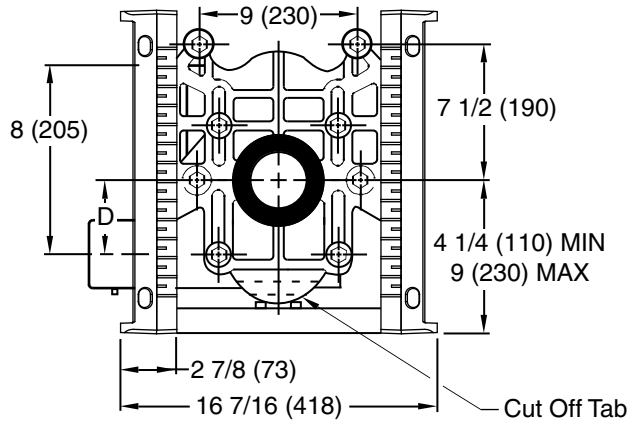

Front View SINGLE

NOTE: Base support must be securely anchored to floor with 1/2" (13) anchors able to withstand a pull-out force of 500 lbs (227 kg). The rear anchor bar must be securely anchored to floor with 1/2" (13) anchors able to withstand a pull-out force of 1000 lbs (454 kg). Pull-out forces are calculated values, no safety factor has been applied.

NOTE: Dimensions shown in parentheses are in millimeters.

- Fig. 0210LY-M54-XX . . .NO-HUB Left Hand
- Fig. 0210RY-M54-XX . . .NO-HUB Right Hand
- Fig. 0210DY-M54-XX. . . NO-HUB Double
- Fig. 0220LY-M54-XX. . . NO-HUB Left Hand Long Barrel
- Fig. 0220RY-M54-XX. . . NO-HUB Right Hand Long Barrel
- Fig. 0220DY-M54-XX . . . NO-HUB Double Long Barrel

A SIZE	D	
	MIN	MAX
4 (100)	5/8 (16)	3 1/8 (79)
5 (125)	5/8 (16)	3 1/8 (79)

Ⓢ dimension = 4" (100) (regularly furnished) consisting of nipple and Adjus-to-Wall coupling permitting adjustment from 3" (76) min. to 4" (100) max.

Jay R. Smith 0210Y or 0220Y-M54-XX complies with and/or exceeds all requirements of ASME A112.6.1M up to 750 lbs.

WE CAN ASSUME NO RESPONSIBILITY FOR USE OF SUPERSEDED OR VOID DATA

DRAWING NUMBER: S0210Y, 0220Y-M54-XX
 SIZE: A
 SCALE: NONE
 DATE: 10/09/07
 APPROVED BY: CL
 CHECKED BY: CL
 DRAWN BY: JJ
 FIGURE NUMBER: 0210Y, 0220Y-M54-XX

REV.	DATE	DESCRIPTION	BY	CKD. BY
A	5-13-08	Revised Note	TBW	CL

WEIGHT POUNDS	VOLUME CUBIC FEET	FIGURE NUMBER 0210Y, 0220Y-M54-XX
---------------	-------------------	---