



JAY R. SMITH MFG. CO.
 DIVISION OF SMITH INDUSTRIES, INC.
 POST OFFICE BOX 3237
 MONTGOMERY, ALABAMA 36109-0237 (USA)
 TEL: 334-277-8520 FAX: 334-272-7396 www.jrsmith.com



MEMBER OF:



LOCATION

ADJUSTABLE FIXTURE SUPPORTS FOR SIPHON JET WATER CLOSETS

DRAWING NUMBER

0210Y,0220Y (-M54-M58)-XH

SIZE

A

SCALE:

NONE

DATE:

2-7-07

APPROVED BY:

AM

CHECKED BY:

AM

DRAWN BY:

RN

WE CAN ASSUME NO RESPONSIBILITY FOR USE OF SUPERSEDED OR VOID DATA

DIMENSIONS ARE SUBJECT TO MANUFACTURERS TOLERANCE AND CHANGE WITHOUT NOTICE

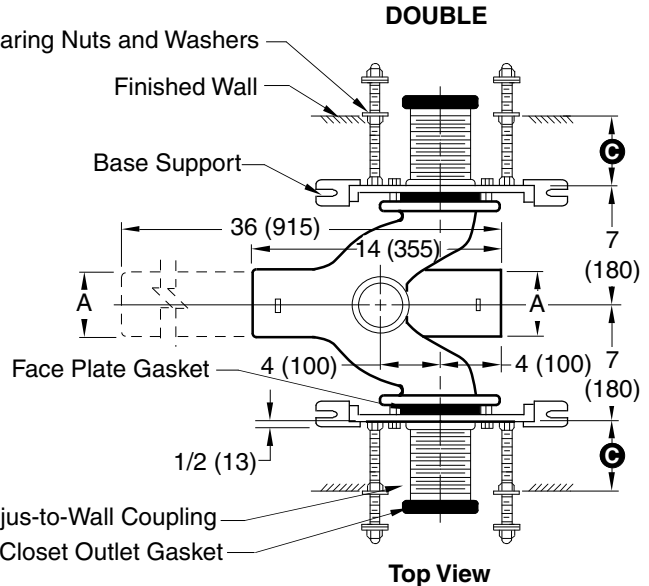
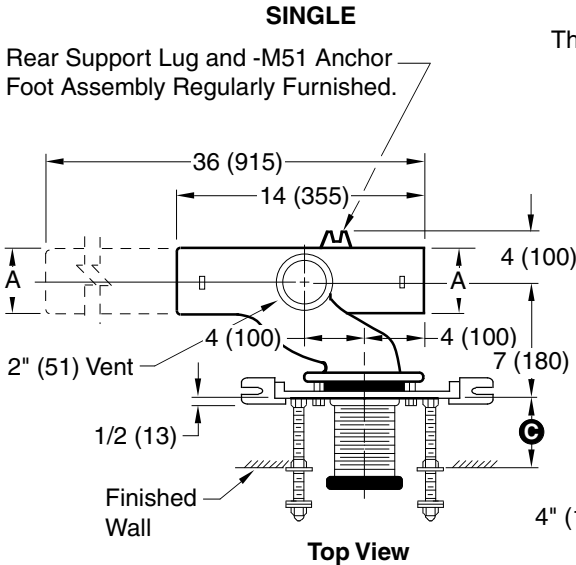

NOTE: Base support must be securely anchored to floor (with one 1/2" (13) bolt per base support provided by contractor).

NOTE: All single supports shall have the rear support lug anchored by contractor to assure a rigid installation. The rear support completes the 3 point anchoring system for ultimate stability of the installation.

NOTE: Dimensions shown in parentheses are in millimeters.

Jay R. Smith 0210Y-M54-M58-XH complies with and/or exceeds all requirements of ASME A112.6.1M up to 500 lbs.

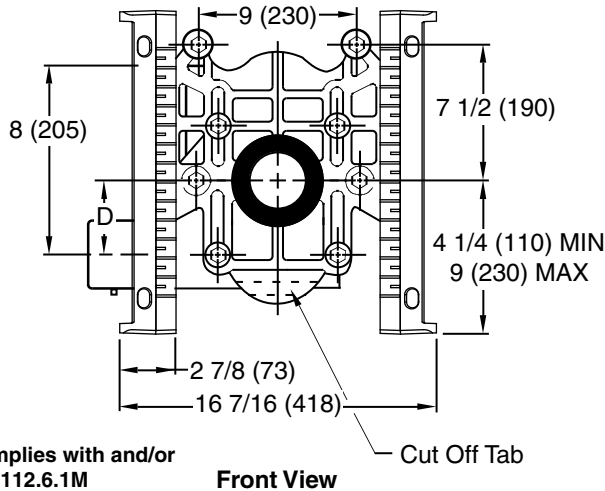

A SIZE	D	
	MIN	MAX
4 (100)	5/8 (16)	3 1/8 (79)
5 (125)	5/8 (16)	3 1/8 (79)

NOTE: When nipple lengths between 3 1/4" (83) and 9 3/4" (247) are specified, the 10" (255) nipple will be supplied. The threaded end of nipple must be cut to specified length by others.

LENGTH	MIN.	MAX.
10(255)	8 3/4"(222)	9 3/4"(247)

- Fig. 0210LY (-M54-M58) . . . NO-HUB Left Hand
- Fig. 0210RY (-M54-M58) . . . NO-HUB Right Hand
- Fig. 0210DY (-M54-M58) . . . NO-HUB Double
- Fig. 0220LY (-M54-M58) . . . NO-HUB Left Hand Long Barrel
- Fig. 0220RY (-M54-M58) . . . NO-HUB Right Hand Long Barrel
- Fig. 0220DY (-M54-M58) . . . NO-HUB Double Long Barrel

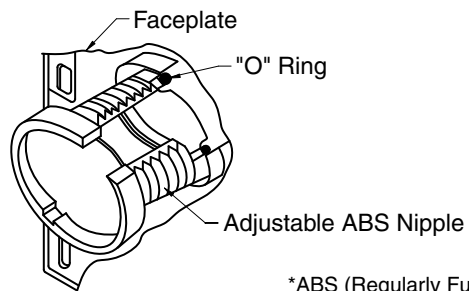

*ABS (Regularly Furnished).

FIGURE NUMBER

REV.	DATE	DESCRIPTION	BY	CKD. BY

WEIGHT POUNDS	VOLUME CUBIC FEET	FIGURE NUMBER
		0210Y,0220Y (-M54-M58)-XH

MODIFICATIONS & VARIATIONS

Ⓞ DIMENSION - ADJUS-TO-WALL TYPE OUTLET CONNECTION

The Smith Adjus-to-Wall outlet connection provides adjustment at the face of the wall at the time the fixture is set; thus, compensating for wall construction variations. The **Ⓞ** dimension is measured from the front of the face plate to the finished wall. To properly determine the length of nipple required, deduct 1" (25) from the **Ⓞ** dimension. When the **Ⓞ** dimension exceeds 7" (180), the -M40 Wide Pipe Chase Support is recommended. The Adjus-to-Wall coupling will provide 1/2" (13) horizontal adjustment in either direction with the coupling extended 5/16" (8) past face of the finished wall.

Ⓞ dimension = 4" (100) (regularly furnished) consisting of nipple and adjus-to-wall coupling permitting adjustment from 3" (76) min. to 4" (100) max.
 *ABS (Regularly Furnished) other length PVC.

NIPPLE LENGTHS AVAILABLE

LENGTH	MIN	Ⓞ	MAX
2 1/2 (64)	2 1/4 (57)	3 1/4 (83)	
*3 1/4 (83)	3 (76)	4 (100)	
*8 1/4 (210)	8 (205)	9 (230)	
10 (255)	9 3/4 (250)	10 3/4 (275)	
12 (305)	11 3/4 (300)	12 3/4 (325)	
15 (380)	14 3/4 (376)	15 3/4 (400)	
18 (455)	17 3/4 (450)	18 3/4 (475)	

NOTE: When nipple lengths between 3 1/4" (83) and 8 1/4" (210) are specified, the 8 1/4" (210) nipple will be supplied. Nipple must be cut to specified length by others.

RECOMMENDED SETTING OF CLOSET OUTLET CONNECTION AND FIXTURE STUDS

Manufacturers have slight differences in the depth of the closet horn and flange thickness of their closets. Usually the fixture support closet connection should extend 5/16" (8) beyond face of finished wall (Dimension "R") and the fixture studs 2 1/4" (57) (Dimension "X"). For exact dimensions please use the formulas below.

DETAIL A Formula for "R" is: $S + 1/16" (2) - D = R$
 S = Depth of closet horn
 1/16" (2) = Distance closet is to set away from finished wall.
 D = 1/2" (13) for felt gasket and 3/8" (10) for neoprene gasket.
 R = Distance coupling should extend beyond finished wall.
 NOTE: When the fixture is installed, closet gasket must be compressed sufficiently to assure a gas and water-tight seal.

DETAIL B Formula for "X" is: $Y + 1/16" (2) + 9/16" (14) = X$
 Y = Thickness of closet wall flange.
 1/16" (2) = Distance closet is to set away from finished wall.
 X = Distance supporting stud should extend beyond finished wall.
 NOTE: Bearing nuts and washers must be set to take full loading from the fixture allowing 1/16" (2) clearance between fixture and wall.

NOTE: Dimensions shown in parentheses are in millimeters.

☐ SUFFIX -M12 EXPOSED FLUSH VALVE SUPPLY SUPPORT

☐ SUFFIX -M13 TILING FRAME - POLYSTYRENE

CONCEALED FLUSH VALVES

A concealed flush valve when used with a blowout water closet support will not clear the face plate. Therefore 4 1/2" (115) to 6 1/2" (165) is required from back of wall to face plate to permit the installation of the concealed flush valve piping.

FIGURE NUMBER	C	12-10-03	Revised Notes Added Millimeters Submittal Update	RN	CL	WEIGHT POUNDS	VOLUME CUBIC FEET	FIGURE NUMBER 0200/0300 Series Back Sheet
	B	6-1-95		EMB	BS			
REV.	DATE	DESCRIPTION	BY	CKD. BY				

DRAWING NUMBER: S0200BS
 SIZE: A
 SCALE: NONE
 DATE: 2-28-86
 APPROVED BY: JD
 CHECKED BY: CR
 DRAWN BY: VGD
 0200/0300 Series Back Sheet
 DIMENSIONS ARE SUBJECT TO MANUFACTURERS TOLERANCE AND CHANGE WITHOUT NOTICE
 WE CAN ASSUME NO RESPONSIBILITY FOR USE OF SUPERSEDED OR VOID DATA