

# ADJUSTABLE FIXTURE SUPPORTS FOR SIPHON JET WATER CLOSETS

## NO-HUB VERTICAL FITTINGS EXTRA HEAVY DUTY - 750 LBS.

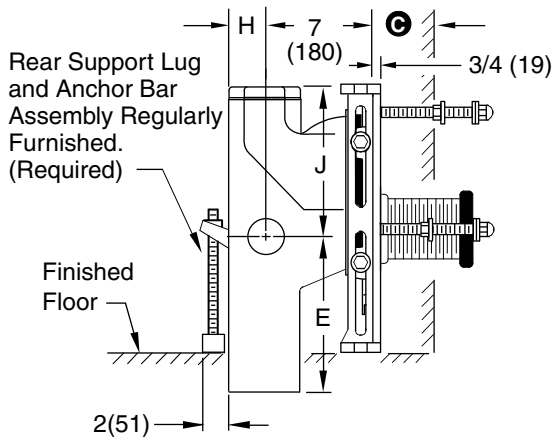

Side View SINGLE

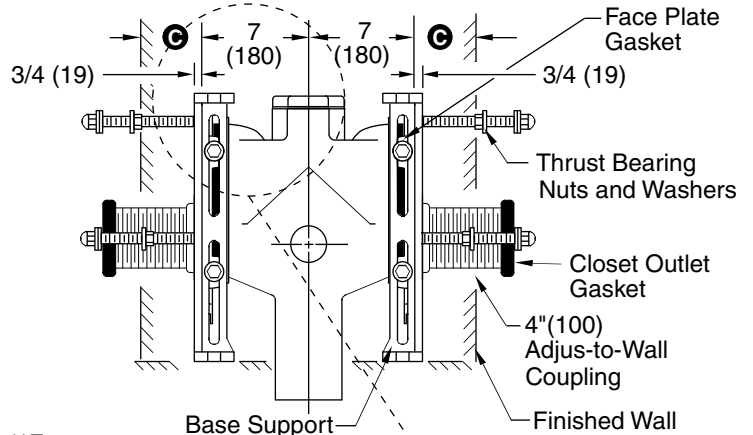

Side View DOUBLE

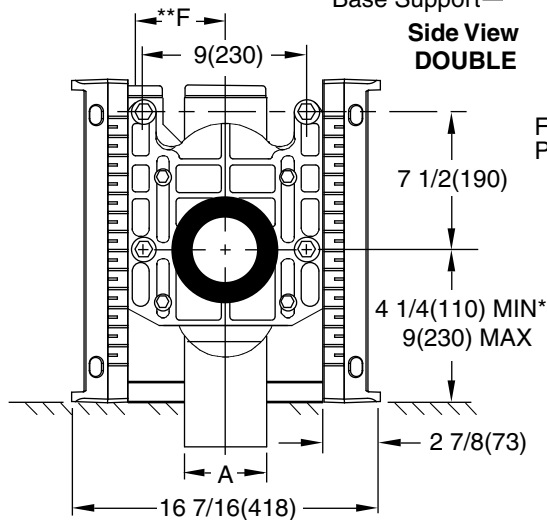

Front View SINGLE

A SIZE	E	**F	H	J
4(100)	14(355)	5 1/4(135)	2 1/4(57)	9(230)
5(125)	11 1/2(290)	6 1/4(160)	2 3/4(70)	11 1/2(290)
6(150)	11 1/2(290)	6 1/4(160)	3 1/4(83)	11 1/2(290)

**NOTE:** Base support must be securely anchored to floor with 1/2" (13) anchors able to withstand a pull-out force of 500 lbs (227 kg). The rear anchor bar must be securely anchored to floor with 1/2" (13) anchors able to withstand a pull-out force of 1000 lbs (454 kg). Pull-out forces are calculated values, no safety factor has been applied.

**NOTE:** Dimensions shown in parentheses are in millimeters.

**NOTE:** When used with concealed flush valve locate face plate behind supply pipe.

**NOTE:** Shallower minimum rough-in dimension available to accommodate lower rough bowls. Specify dimension required.

**NOTE:** 1 1/2(38) or 2(51) NPT inlet available. Add suffix -N.

**\*NOTE:** 9"(230) core drilled hole is required for rough-in 4 1/4(110) thru 6 1/2(165).

**\*\*NOTE:** "F" dimension is from centerline of vent to centerline of stack.

**Fig. 0230Y-M58-M54-XX...NO-HUB**  
**Fig. 0230DY-M58-M54-XX...NO-HUB DOUBLE**

Jay R. Smith 0230Y-M58-M54-XX complies with and/or exceeds all requirements of ASME A112.6.1M up to 750 lbs.

**NOTE:** When nipple lengths between 3 1/4"(83) and 9 3/4"(247) are specified, the 10"(255) nipple will be supplied. The threaded end of nipple must be cut to specified length by others.

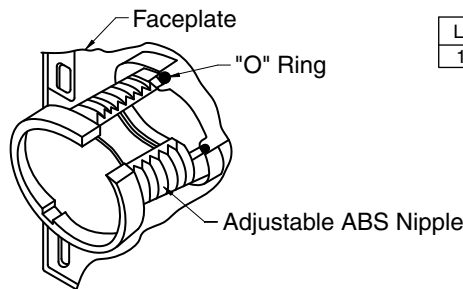

LENGTH	MIN.	MAX.
10(255)	8 3/4"(222)	9 3/4"(247)

\*ABS (Regularly Furnished).

DRAWING NUMBER: S0230Y-M58-M54-XX  
 SIZE: A  
 SCALE: NONE  
 DATE: 10/08/07  
 APPROVED BY: CL  
 CHECKED BY: CL  
 DRAWN BY: JJ  
 FIGURE NUMBER: 0230Y-M58-M54-XX

WE CAN ASSUME NO RESPONSIBILITY FOR USE OF SUPERSEDED OR VOID DATA

REV.	DATE	DESCRIPTION	BY	CKD. BY	WEIGHT POUNDS	VOLUME CUBIC FEET	FIGURE NUMBER
C	11/20/09	3/4 (19) was 1/2 (13)	JJ	CL			0230Y-M58-M54-XX
B	5-13-08	Revised Note	TBW	CL			
A	11/20/07	Moved J & E Dimensions	JJ	CL			