

NO-HUB COMPACT FIXTURE SUPPORTS
WITH VERTICAL OFFSET FITTINGS FOR SIPHON JET WATER CLOSETS
WITH SANITARY SWEEP INLETS

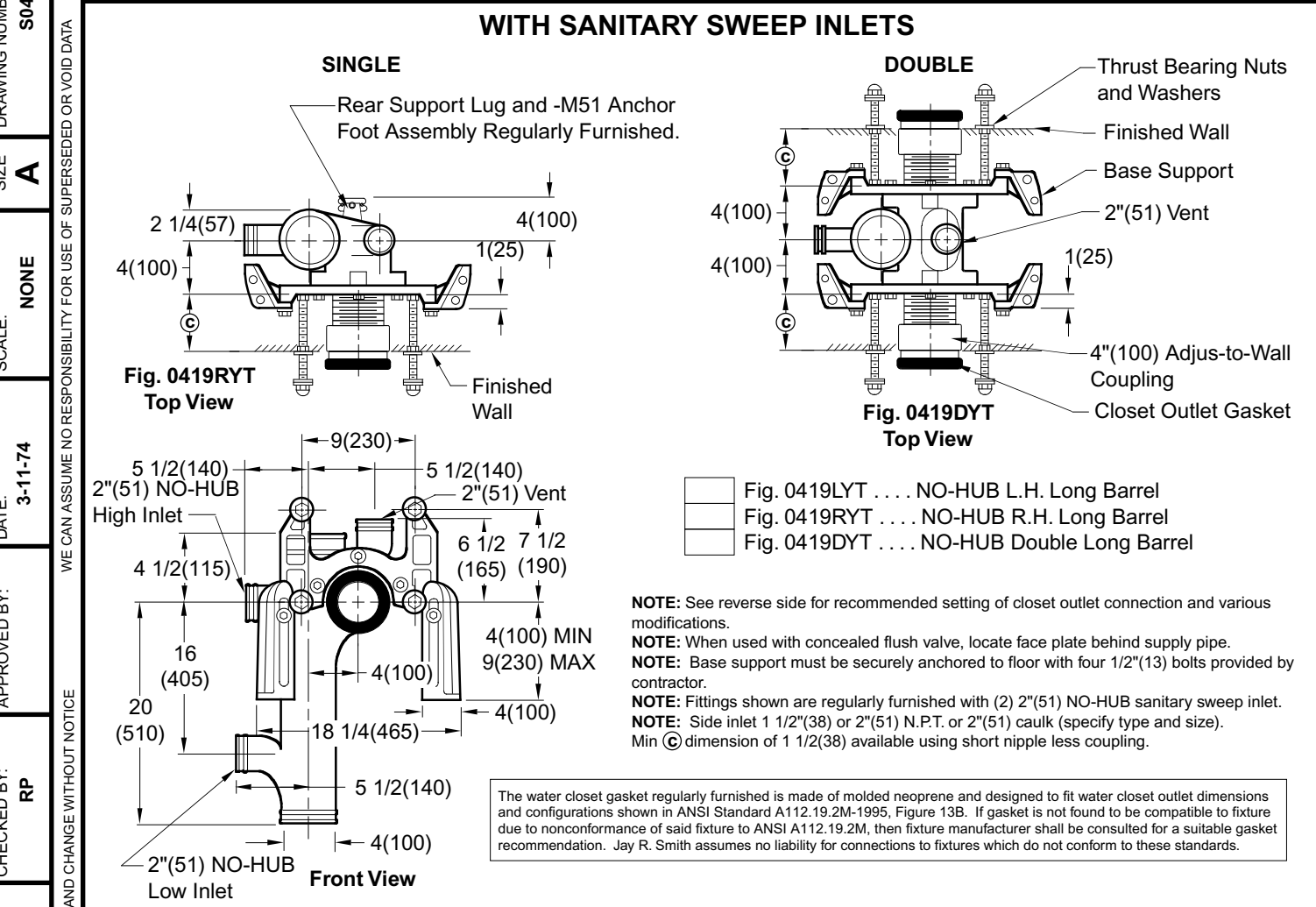

- Fig. 0419LYT . . . NO-HUB L.H. Long Barrel
- Fig. 0419RYT . . . NO-HUB R.H. Long Barrel
- Fig. 0419DYT . . . NO-HUB Double Long Barrel

NOTE: See reverse side for recommended setting of closet outlet connection and various modifications.
NOTE: When used with concealed flush valve, locate face plate behind supply pipe.
NOTE: Base support must be securely anchored to floor with four 1/2"(13) bolts provided by contractor.
NOTE: Fittings shown are regularly furnished with (2) 2"(51) NO-HUB sanitary sweep inlet.
NOTE: Side inlet 1 1/2"(38) or 2"(51) N.P.T. or 2"(51) caulk (specify type and size). Min © dimension of 1 1/2"(38) available using short nipple less coupling.

The water closet gasket regularly furnished is made of molded neoprene and designed to fit water closet outlet dimensions and configurations shown in ANSI Standard A112.19.2M-1995, Figure 13B. If gasket is not found to be compatible to fixture due to nonconformance of said fixture to ANSI A112.19.2M, then fixture manufacturer shall be consulted for a suitable gasket recommendation. Jay R. Smith assumes no liability for connections to fixtures which do not conform to these standards.

© DIMENSION - ADJUS-TO-WALL TYPE OUTLET CONNECTION

The Smith Adjus-to-Wall outlet connection provides adjustment at the face of the wall at the time the fixture is set; thus, compensating for wall construction variations. The © dimension is measured from the front of the face plate to the finished wall. To properly determine the length of nipple required, deduct 1" (25) from the © dimension. The Adjus-to-Wall coupling will provide 1/2" (13) horizontal adjustment in either direction with the coupling extended 5/16" (8) past face of the finished wall.

© dimension = 4" (100) (regularly furnished) consisting of nipple and Adjus-to-Wall coupling permitting adjustment from 3" (76) min. to 4" (100) max.

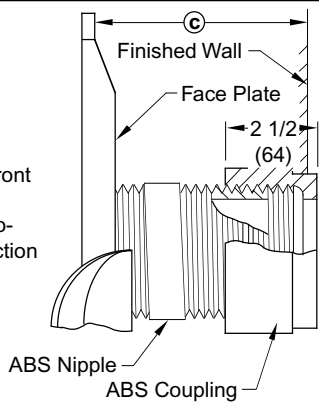

NOTE: Dimensions shown in parentheses are in millimeters.

NIPPLE LENGTHS AVAILABLE

LENGTH	MIN	©	MAX
2 1/2 (64)	2 1/4 (57)	3 1/4 (83)	
*3 1/4 (83)	3 (76)	4 (100)	
*8 1/4 (210)	8 (205)	9 (230)	
10 (255)	9 3/4 (250)	10 3/4 (275)	
12 (305)	11 3/4 (300)	12 3/4 (325)	
15 (380)	14 3/4 (375)	15 3/4 (400)	
18 (455)	17 3/4 (450)	18 3/4 (475)	

NOTE: When nipple lengths between 3 1/4" (83) and 8 1/4" (210) are specified, the 8 1/4" (210) nipple will be supplied. Nipple must be cut to specified length by others.

*ABS (Regularly Furnished) other lengths PVC.

DRAWING NUMBER: S0419YT
 SIZE: A
 SCALE: NONE
 DATE: 3-11-74
 APPROVED BY: RP
 CHECKED BY: JH
 DRAWN BY: JH
 FIGURE NUMBER: 0419YT

WE CAN ASSUME NO RESPONSIBILITY FOR USE OF SUPERSEDED OR VOID DATA

REV.	DATE	DESCRIPTION	BY	CKD. BY	WEIGHT POUNDS	VOLUME CUBIC FEET	FIGURE NUMBER
E	7-1-98	Submittal Update	ASL	BS			0419YT
D	3-5-97	Added Millimeters	EMB	BS			
C	5-18-94	Submittal Update	EMB	BS			

DRAWING NUMBER S0100BS **SIZE A** **SCALE: NONE** **DATE: 1-16-85** **APPROVED BY: JD** **CHECKED BY: CR** **DRAWN BY: VGD**

MODIFICATIONS & VARIATIONS FOR SIPHON JET WATER CLOSETS

RECOMMENDED SETTING OF CLOSET OUTLET CONNECTION AND FIXTURE STUDS

Manufacturers have slight differences in the depth of the closet horn and flange thickness of their closets. Usually the fixture support closet connection should extend 5/16" (8) beyond face of finished wall (Dimension "R") and the fixture studs 2 1/4" (57) (Dimension "X"). For exact dimensions please use the formulas below.

DETAIL A Formula for "R" is: $S + 1/16" (2) - D = R$.
 S = Depth of closet horn
 1/16" (2) = Distance closet is to set away from finished wall.
 D = 1/2" (13) for felt gasket and 3/8" (10) for neoprene gasket.
 R = Distance coupling should extend beyond finished wall.
 NOTE: When the fixture is installed, closet gasket must be compressed sufficiently to assure a gas and water-tight seal.

DETAIL B Formula for "X" is: $Y + 1/16" (2) + 9/16" (14) = X$.
 Y = Thickness of closet wall flange.
 1/16" (2) = Distance closet is to set away from finished wall.
 X = Distance supporting stud should extend beyond finished wall.
 NOTE: Bearing nuts and washers must be set to take full loading from the fixture allowing 1/16" (2) clearance between fixture and wall.

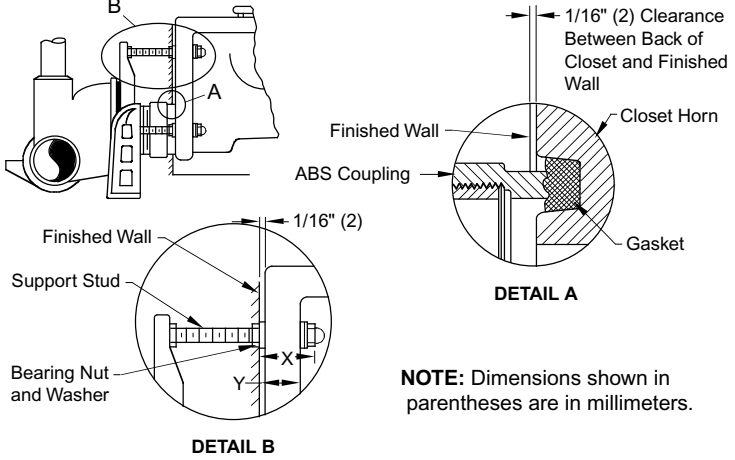

OPTIONAL CLOSET OUTLET CONNECTIONS

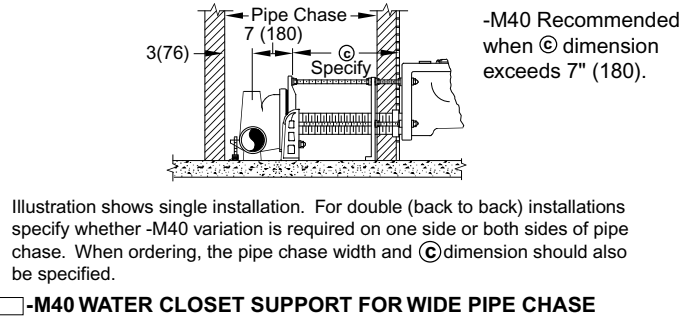
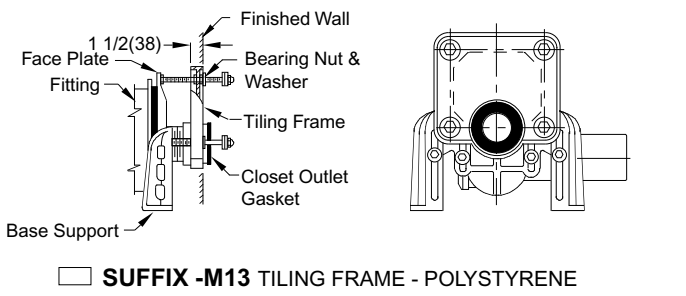
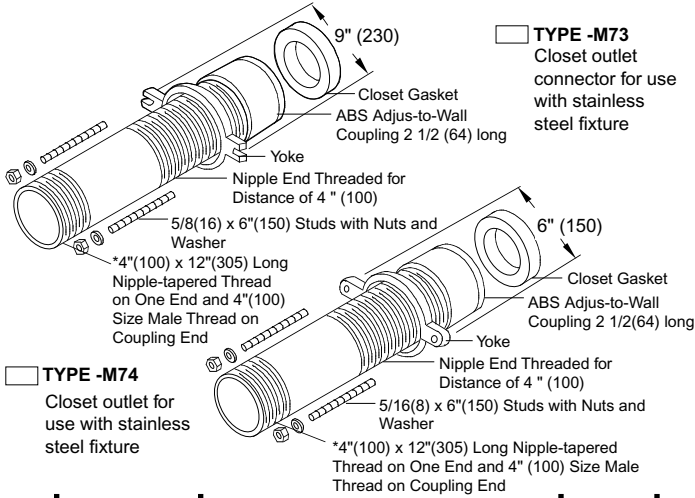
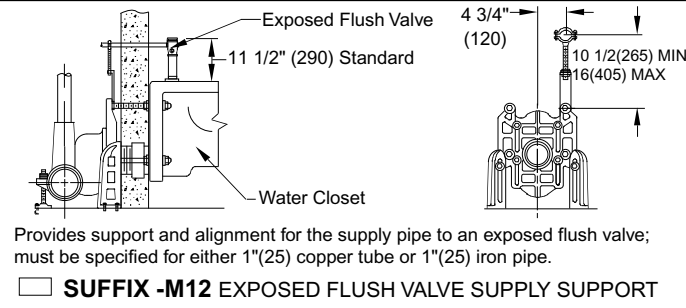
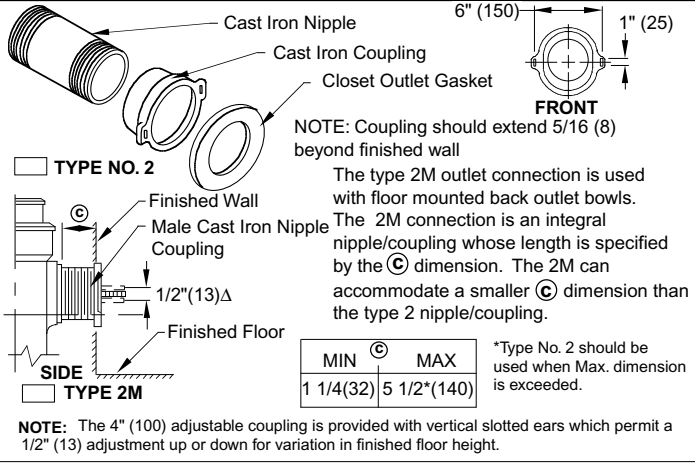

100/400 Series Back Sheet

WE CAN ASSUME NO RESPONSIBILITY FOR USE OF SUPERSEDED OR VOID DATA

DIMENSIONS ARE SUBJECT TO MANUFACTURERS TOLERANCE AND CHANGE WITHOUT NOTICE

C	12-10-03	Added Note	RN	CL	WEIGHT	VOLUME	FIGURE NUMBER
B	2-26-96	Added Millimeters	EMB	BS	POUNDS	CUBIC FEET	100/400 Series
A	7-1-93	Submittal Update	EMB	BS			Back Sheet
REV.	DATE	DESCRIPTION	BY	CKD. BY			