

SMITH® JAY R. SMITH MFG. CO.
 DIVISION OF SMITH INDUSTRIES, INC.
 POST OFFICE BOX 3237
 MONTGOMERY, ALABAMA 36109-0237 (USA)
 TEL: 334-277-8520 FAX: 334-272-7396 www.jrsmith.com



LOCATION

FIXTURE SUPPORT FLOOR MOUNTED TYPE WITH TOP SUPPORTING PLATE

FOR BLOWOUT AND WASHOUT URINALS WITH CONCEALED WALL HANGER

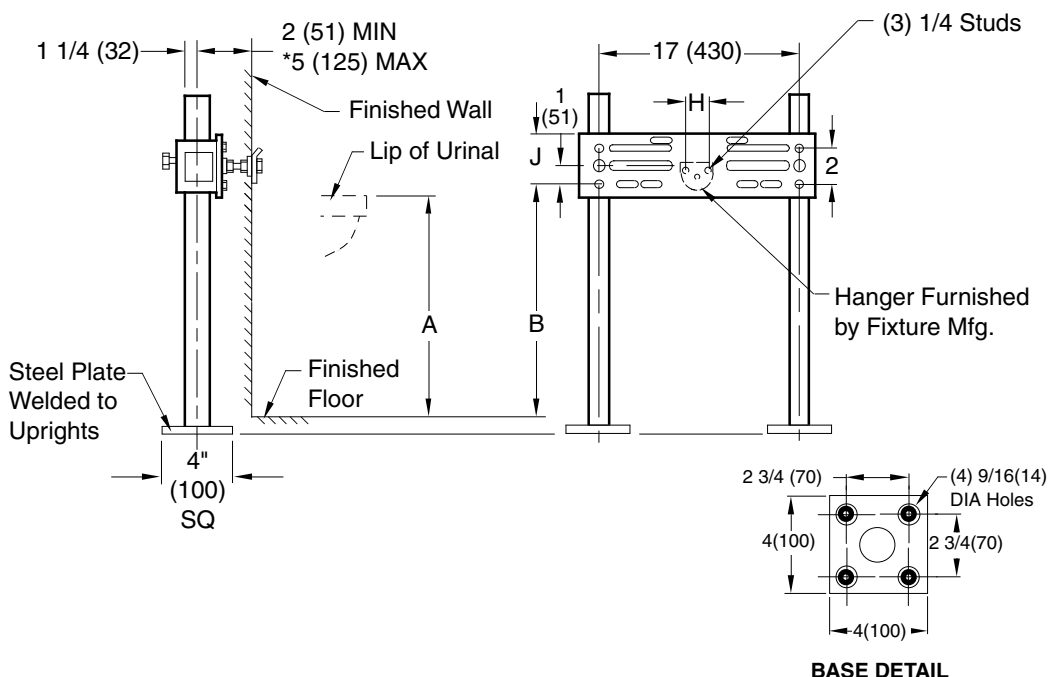

ROUGH-IN TABLE

FIXTURE MFG.	NAME	NUMBER	A	B	H	J

NOTE: Uses P/N 70084-86-6 Plate (Modified)

*This dimension can be increased when fixture support is to be installed behind the wall (specify when required and wall thickness).

NOTE: Dimension shown in parentheses are in millimeters.

DRAWING NUMBER
S0643 (Allbrook)

SIZE
A

SCALE:
NONE

DATE:
10-6-98

APPROVED BY:

CHECKED BY:

DRAWN BY:
CMD

0643

WE CAN ASSUME NO RESPONSIBILITY FOR USE OF SUPERSEDED OR VOID DATA

DIMENSIONS ARE SUBJECT TO MANUFACTURERS TOLERANCE AND CHANGE WITHOUT NOTICE

FIGURE NUMBER	A	11-2-98	Added note	CMD	BW
REV.	DATE	DESCRIPTION	BY	CKD. BY	

WEIGHT POUNDS	VOLUME CUBIC FEET

FIGURE NUMBER
0643