



JAY R. SMITH MFG. CO.
 DIVISION OF SMITH INDUSTRIES, INC.
 POST OFFICE BOX 3237
 MONTGOMERY, ALABAMA 36109-0237 (USA)
 TEL: 334-277-8520 FAX: 334-272-7396 www.jrsmith.com



MEMBER OF:



LOCATION

SUFFIX -M12 EXPOSED FLUSH VALVE SUPPLY SUPPORT

DRAWING NUMBER
S-M12

SIZE
A

SCALE:
NONE

DATE:
12-15-87

APPROVED BY:
TD

CHECKED BY:
BS

DRAWN BY:
EMB

WE CAN ASSUME NO RESPONSIBILITY FOR USE OF SUPERSEDED OR VOID DATA

DIMENSIONS ARE SUBJECT TO MANUFACTURERS TOLERANCE AND CHANGE WITHOUT NOTICE

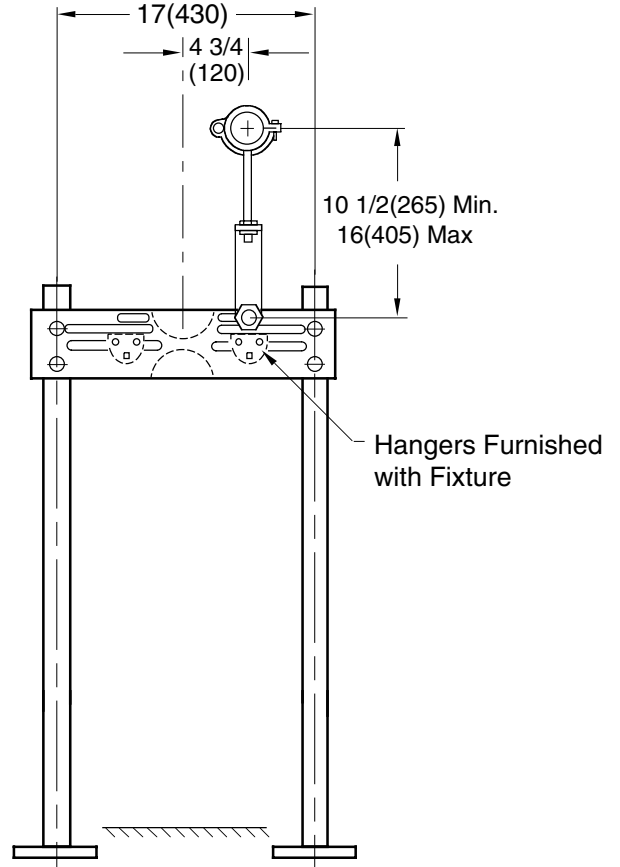
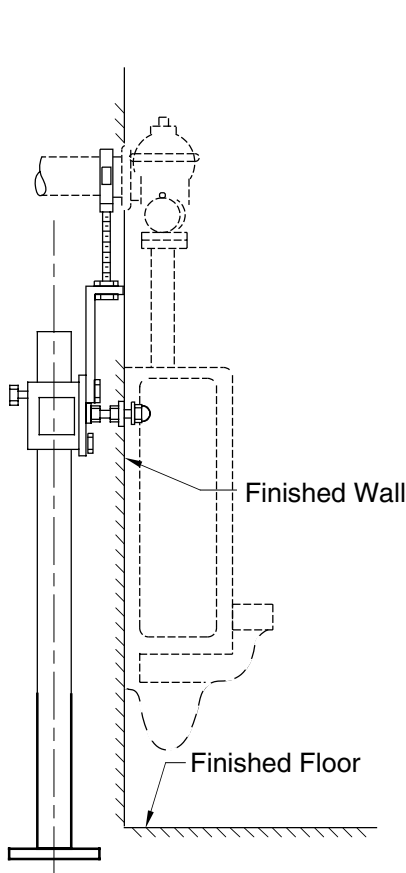

REGULARLY FURNISHED:

3/4"(19) Copper Plates Hanger with Steel Angle Clip and Adjustable Threaded Stud.

VARIATIONS:

- For 1/2"(13) Pipe
- For 3/4"(19) Pipe
- For 1"(25) Pipe
- For 1 1/4"(32) Pipe
- For 1 1/2"(38) Pipe

Dimensions shown in parenthesis are in millimeters.

-M12

FIGURE NUMBER

B A	4-17-95 10-89	Revised and Redrawn Changed Variations	CMB EMB	BS
REV.	DATE	DESCRIPTION	BY	CKD. BY

WEIGHT
POUNDS

VOLUME
CUBIC FEET

FIGURE NUMBER
-M12