

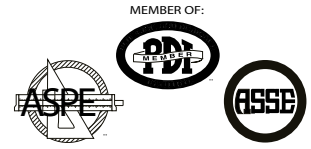

JAY R. SMITH MFG. CO.
 DIVISION OF SMITH INDUSTRIES, INC.
 POST OFFICE BOX 3237
 MONTGOMERY, ALABAMA 36109-0237 (USA)
 TEL: 334-277-8520 FAX: 334-272-7396 www.jrsmith.com



LOCATION

FACEPLATE WITH ADJUSTABLE NIPPLE AND "O" RING

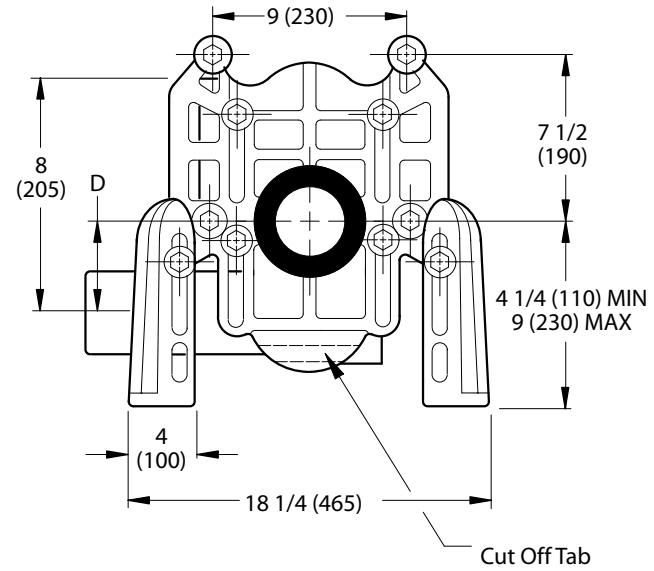

Front View

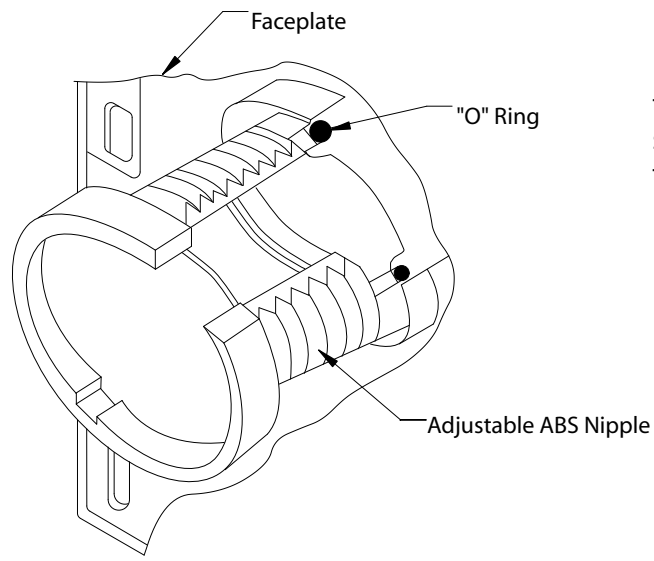

NOTE: The M58 suffix is furnished with the 0200-M58 series faceplate and base supports, with the faceplate machined for the "O" ring seal and the adjustable 10" ABS nipple.

DRAWING NUMBER
SM58

SIZE
A

SCALE:
NONE

DATE:
7-22-97

APPROVED BY:
SB

CHECKED BY:
SLB

DRAWN BY:
EMB

M58

WE CAN ASSUME NO RESPONSIBILITY FOR USE OF SUPERSEDED OR VOID DATA

REV.	DATE	DESCRIPTION	BY	CKD. BY
A	2-23-98	Chg'd Dwg.	EMB	BS

WEIGHT POUNDS	VOLUME CUBIC FEET

FIGURE NUMBER
M58