

**OUTLET CONNECTION ASSEMBLY  
 FOR USE WITH PENAL TYPE FIXTURES  
 WITH OUTLET STUDS ON 9"(230) CENTERS**

**INSTALLATION**

Install as shown in plan view. 5/8(16) studs are screwed into outlet tappings on ware and gasket is placed in horn. Fixture is bolted to wall with bolts supplied by fixture manufacturer. The 5/8(16) outlet studs are passed through the ears of yoke. With fixture bolted snugly to wall, the Adjus-to-Wall coupling is rotated snug against the gasket. Final compression is made by tightening down yoke against back of coupling.

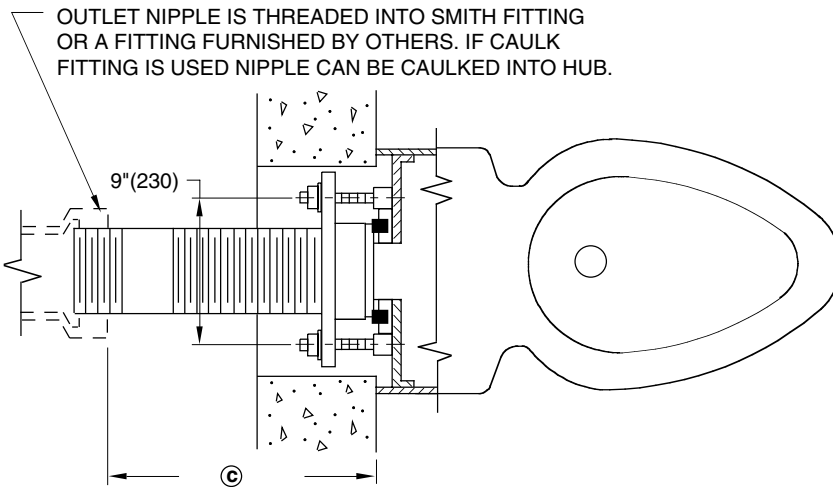
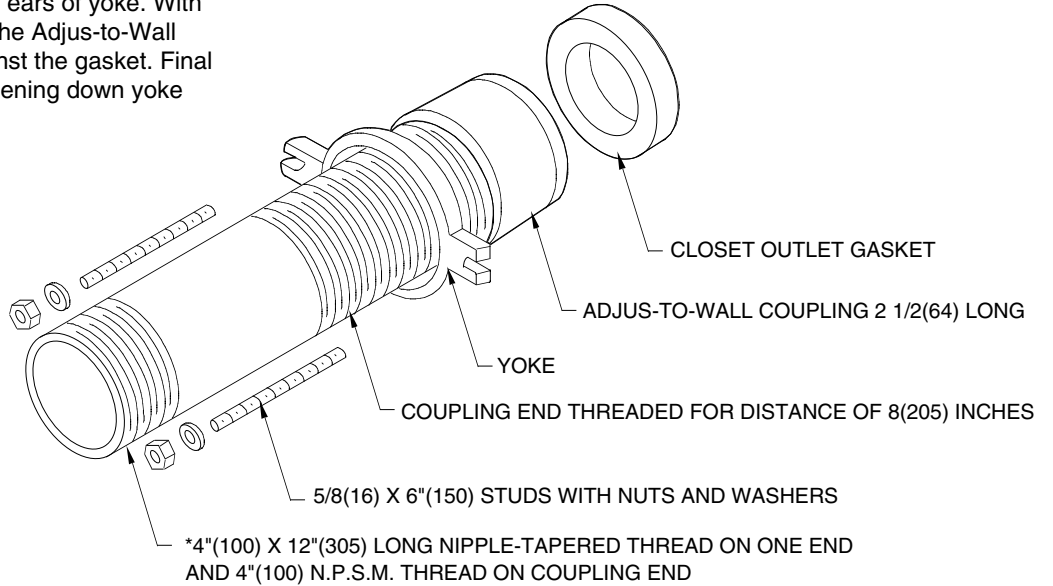

**NIPPLE LENGTHS AVAILABLE**

A	MIN	©	MAX
2 1/2(64)	2 3/4(70)		3 3/4(95)
3 1/4(83)	3(76)		4 1/2(115)
4 1/2(115)	4 1/4(110)		5 3/4(145)
5 1/4(135)	5(125)		6 1/2(165)
6 1/4(160)	6(150)		7 1/2(190)
7(180)	6 3/4(170)		8 1/4(210)
8 1/4(210)	8(205)		9 1/2(240)
10(255)	9 3/4(250)		11 1/4(285)
12(305)	11 3/4(300)		13 1/4(335)
15(380)	14 3/4(375)		16 1/4(415)
18(455)	17 3/4(450)		19 1/4(490)

PLAN VIEW OF TYPICAL INSTALLATION

**NOTE:** Dimensions shown in parenthesis are in millimeters.

\*12"(305) Long nipple regularly furnished. Other lengths are available when specified. See chart above for other lengths and

© dimension min. and max.

DRAWING NUMBER S-M73  
 SIZE A  
 SCALE: NONE  
 DATE: 10-11-74  
 APPROVED BY: R.P.  
 CHECKED BY: R.P.  
 DRAWN BY: D.A.  
**-M73**

WE CAN ASSUME NO RESPONSIBILITY FOR USE OF SUPERSEDED OR VOID DATA  
 DIMENSIONS ARE SUBJECT TO MANUFACTURERS TOLERANCE AND CHANGE WITHOUT NOTICE

FIGURE NUMBER	A	4-11-95	REVISED DIMENSIONS	CMB	WEIGHT POUNDS	VOLUME CUBIC FEET	FIGURE NUMBER
REV.	DATE	DESCRIPTION	BY	CKD. BY			<b>-M73</b>