

DRAWING NUMBER
s2051

SIZE
A

SCALE:
NONE

DATE:
4-7-08

APPROVED BY:
CEL

CHECKED BY:
CL

DRAWN BY:
TBW

WE CAN ASSUME NO RESPONSIBILITY FOR USE OF SUPERSEDED OR VOID DATA

FLOOR OR SHOWER DRAIN WITH ADJUSTABLE STRAINER HEAD

FLASHING STRAINER TYPE

FUNCTION: Designed for clamping Altro Vinyl Traffic Flooring or other waterproofing materials at the finished floor level.

FREE AREA
7 SQ IN
(45) SQ CM

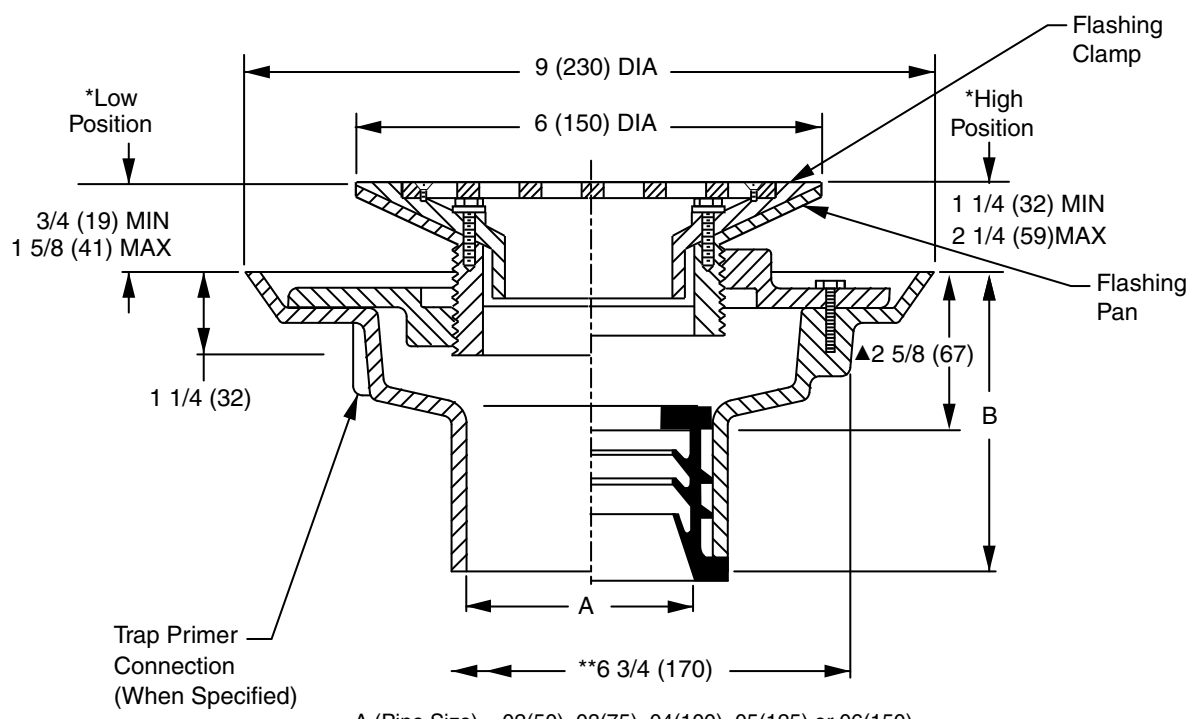

A (Pipe Size) = 02(50), 03(75), 04(100), 05(125) or 06(150)

- Fig. 2051Y NO-HUB Outlet
- Fig. 2051C Caulk Outlet

▲ This dimension to internal stop of Speedi-Set Gasket
 * Collar is reversible to obtain extreme high and low strainer positions.
 ** MIN 6 3/4"(170) hole required for core drilled application.
 NOTE: 05(125) and 06(150) outlet size available in NO-HUB only.

A SIZE	02(50), 03(75), 04(100), 05(125) or 06(150)
B	04(100 for NO-HUB, Caulk and Speedi-Set, 3(76) for Threaded

REGULARLY FURNISHED:
 Duco Cast Iron Body with Flashing Collar and Adjustable Flashing Type Nickel Bronze Strainer.

NOTE: Dimensions shown in parentheses are in millimeters.

- VARIATIONS:**
- L Speedi-Set Service Weight 2(50), 3(75) & 4"(100) only
 - LXH Speedi-Set Extra Heavy 2(50), 3(75) & 4"(100) only
 - Trap Primer Connection -P050 1/2" (13) & -P075 3/4" (19)
 - Vandal Proof Screws -U
 - T Threaded Outlet

- OPTIONAL MATERIALS:**
- Galvanized Cast Iron Body -G
 - Polished Bronze Strainer -PB
 - Chrome Plated Strainer -CP

2051

FIGURE NUMBER

REV.	DATE	DESCRIPTION	BY	CKD. BY

WEIGHT POUNDS

VOLUME CUBIC FEET

FIGURE NUMBER

2051