

**SMITH® JAY R. SMITH MFG. CO.®**  
 DIVISION OF SMITH INDUSTRIES, INC.  
 POST OFFICE BOX 3237  
 MONTGOMERY, ALABAMA 36109-0237 (USA)  
 TEL: 334-277-8520 FAX: 334-272-7396 www.jrsmith.com



MEMBER OF:

LOCATION

# FLOOR DRAINS WITH HEAVY DUTY TRACTOR GRATE

## 15" (380) ROUND TOP - HEAVY DUTY DRAINS

**FUNCTION:** Used in heavy traffic areas where waste water contains no sediment or debris and construction requires a shallow body. Large top area permits use where high flow is anticipated.

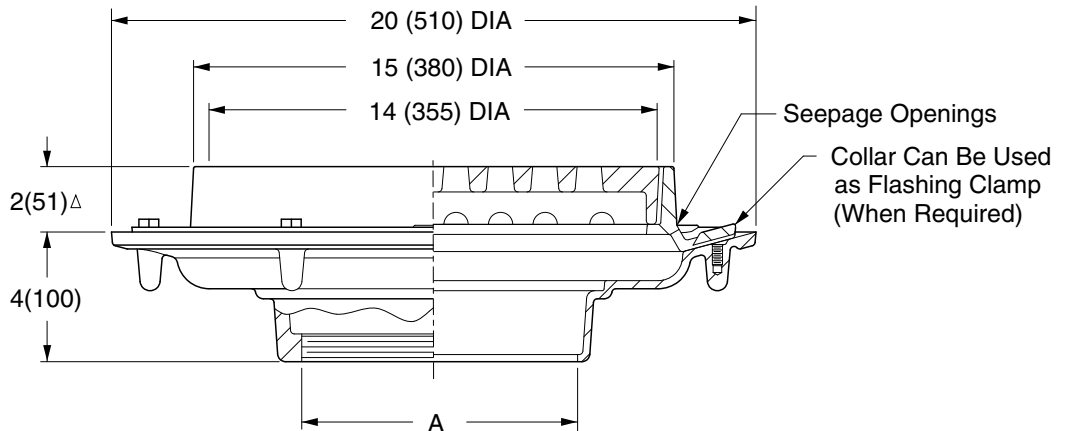

A (Pipe Size) = 02(50), 03(75), 04(100), 05(125), 06(150) or 08(200)

- Fig. 2143C.....CAULK OUTLET
- Fig. 2143T.....THREADED OUTLET

Δ Add 1/4" (6) when bronze top is specified.

**REGULARLY FURNISHED:**  
 Duco Cast Iron Body and Flashing Collar with Cast Iron ADA Tractor Grate.

- VARIATIONS:**
- Dome Grate -D
  - Flat Bottom Strainer -FBS
  - NO-HUB Adaptor (Specify Fig. 2646Y)
  - Square Top -S
  - Vandal Proof -U
  - 4"(100) High Collar -HC4

- OPTIONAL MATERIALS:**
- Ductile Iron Grate -M
  - Galvanized Cast Iron -G
  - Nickel Bronze Top -NB
  - Polished Bronze Top -PB
  - Stainless Steel (Specify Fig. 9733)

**NOTE:** Dimensions shown in parentheses are in millimeters.

DRAWING NUMBER  
S2143

SIZE  
A

SCALE:  
NONE

DATE:  
5-17-85

APPROVED BY:  
TD

CHECKED BY:  
TD

DRAWN BY:  
PJ

**2143**

DIMENSIONS ARE SUBJECT TO MANUFACTURERS TOLERANCE AND CHANGE WITHOUT NOTICE WE CAN ASSUME NO RESPONSIBILITY FOR USE OF SUPERSEDED OR VOID DATA

REV.	DATE	DESCRIPTION	BY	CKD. BY	WEIGHT POUNDS	VOLUME CUBIC FEET	FIGURE NUMBER
FED	11/18/10	Added ADA to Grate	JJ	CL			<b>2143</b>
	10/10/05	Corrected Outlet View	JJ	BW			
	1-18-99	Submittal redraw	CMD	BS			