

HEAVY DUTY FLOOR DRAIN

Free Area
 75 SQ IN
 (484 SQCM)

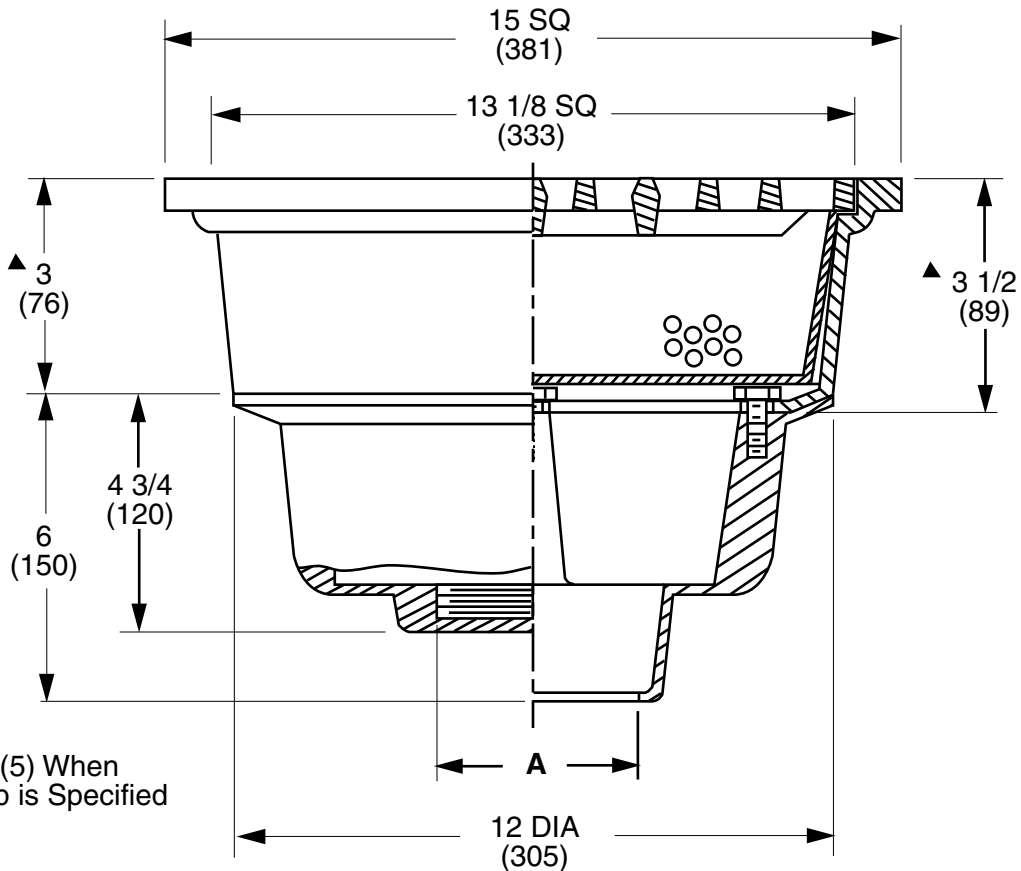

A (Pipe Size) = 2 (50), 3 (75), 4 (100), 5 (125) or 6 (150)

- FIG 2295C.....Caulk Outlet Regular
- FIG 2295-Y.... No Hub Outlet

REGULARY FURNISHED:
 Duco Cast Iron Body and
 Flashing Collar with Secured
 Ductile Iron Grate and
 Stainless Steel Sediment Bucket.

VARIATIONS:

- Vandal Proof (U)
- Threaded Outlet (T)
- Speedi-Set Outlet
 (2 (50), 3 (75), 4 (100) Size
 Only Specify XH or SW)
- Side Outlet
- Flat Bottom Strainer (FBS)

OPTIONAL MATERIALS:

- Galvanized(G)
- Polished Bronze Top (PB)
- Nickel Bronze Top (NB)

NOTE: Dimensions shown in
 parentheses are in
 millimeters.

DRAWING NUMBER
 s2295

SIZE
 A

SCALE:
 NONE

DATE:
 5/24/02

APPROVED BY:
 CEL

CHECKED BY:
 CL

DRAWN BY:
 RN

2295

WE CAN ASSUME NO RESPONSIBILITY FOR USE OF SUPERSEDED OR VOID DATA

DIMENSIONS ARE SUBJECT TO MANUFACTURERS TOLERANCE AND CHANGE WITHOUT NOTICE

FIGURE
 NUMBER

| REV. | DATE | DESCRIPTION | BY | CKD. BY |
|------|------|-------------|----|---------|
| | | | | |

WEIGHT
 POUNDS

VOLUME
 CUBIC FEET

FIGURE NUMBER

2295