

F

**SMITH® JAY R. SMITH MFG. CO.®**  
 DIVISION OF SMITH INDUSTRIES, INC.  
 POST OFFICE BOX 3237  
 MONTGOMERY, ALABAMA 36109-0237 (USA)  
 TEL: 334-277-8520 FAX: 334-272-7396 www.jrsmith.com



LOCATION

# FLOOR DRAINS

## INTEGRAL TRAP AND FLOOR-LEVEL CLEANOUT DRAINS

**FUNCTION:** Used in moderate traffic areas where deep trap seal, floor level cleanout and shallow side outlet rough-in and required where limited space is available. Drain includes these features in one compact casting.

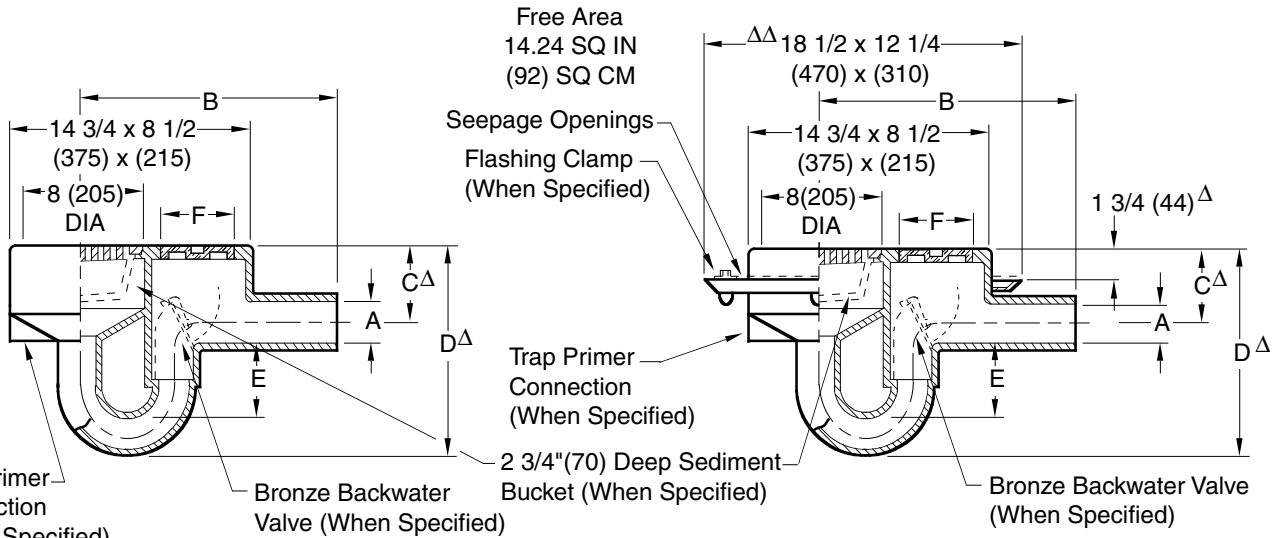

Fig. 2510S ... LESS FLANGE

Fig. 2515S ... WITH FLANGE

**NOTE:** When bucket is specified grate cannot be inserted unless bucket is put in place.

| A<br>SIZE   | B               | C              | D               | E<br>SEAL      | F<br>N.P.T. |
|-------------|-----------------|----------------|-----------------|----------------|-------------|
| 02<br>(50)  | 16<br>(405)     | 4 1/4<br>(110) | 11 3/4<br>(300) | 4<br>(100)     | 5<br>(125)  |
| 03<br>(75)  | 15 3/4<br>(400) | 4<br>(100)     | 13 1/2<br>(345) | 4 1/2<br>(115) | 5<br>(125)  |
| 04<br>(100) | 16<br>(405)     | 4 1/2<br>(115) | 15 3/4<br>(400) | 4 3/4<br>(120) | 5<br>(125)  |

Δ 2" (50) size 18 3/4 (475) x 12 1/2 (320)

■ Meets ANSI Spec A 112.21-1M

Δ add 3/16" (5) when bronze top is specified

**SPIGOT OUTLET  
 SIZED FOR NO HUB  
 AND/OR SERVICE WEIGHT**

**REGULARLY FURNISHED:**

Duco Cast Iron Body and Grate with Bronze Cleanout Plug.

**VARIATIONS:**

- Auxiliary Inlet -N 03" (75) and 04" (100) sizes only -N15 1 1/2" (38), -N2 2" (51))
- Backwater Valve -V
- Dome Grate -D
- Flashing Clamp -C (Fig. 2515 only)
- Hinged Grate -H
- "Safe-Set" Sediment Bucket -B
- Trap Primer Connection -P050 1/2" (13) & -P075 3/4" (19)
- Vandal Proof Grate -U

**OPTIONAL MATERIALS:**

- Galvanized Cast Iron -G
- Nickel Bronze Top -NB
- Polished Bronze Top -PB
- Stainless Steel (Specify Fig. 9750)

**NOTE:** Dimensions shown in parentheses are in millimeters.

DRAWING NUMBER  
S2510

SIZE  
A

SCALE:  
NONE

DATE:  
5-17-85

APPROVED BY:  
TD

CHECKED BY:  
TD

DRAWN BY:  
PJ

2510, 2515

WE CAN ASSUME NO RESPONSIBILITY FOR USE OF SUPERSEDED OR VOID DATA

DIMENSIONS ARE SUBJECT TO MANUFACTURERS TOLERANCE AND CHANGE WITHOUT NOTICE

|               |        |                   |                                       |            |          |                  |                      |                                    |
|---------------|--------|-------------------|---------------------------------------|------------|----------|------------------|----------------------|------------------------------------|
| FIGURE NUMBER | F<br>E | 5-28-98<br>4-9-97 | Submittal Update<br>Added Millimeters | ASL<br>EMB | BS<br>BS | WEIGHT<br>POUNDS | VOLUME<br>CUBIC FEET | FIGURE NUMBER<br><b>2510, 2515</b> |
| REV.          | DATE   | DESCRIPTION       |                                       | BY         | CKD. BY  |                  |                      |                                    |