

# 1/4 TURN QUARTERHORSE NON-FREEZE WALL HYDRANT

## BRONZE BOX TYPE "TWIN-TEMP" FOR HOT AND COLD WATER

**FUNCTION:** Provides positive non-freeze protection where water is required at the outside of the building. Ideal for use in food handling areas, dairies and other places where both hot and cold water are desired. The recessed box conceals the hose connection and operating mechanisms. 1/4 turn of the key allows full flow to be obtained. The locking cover prevents unauthorized use.

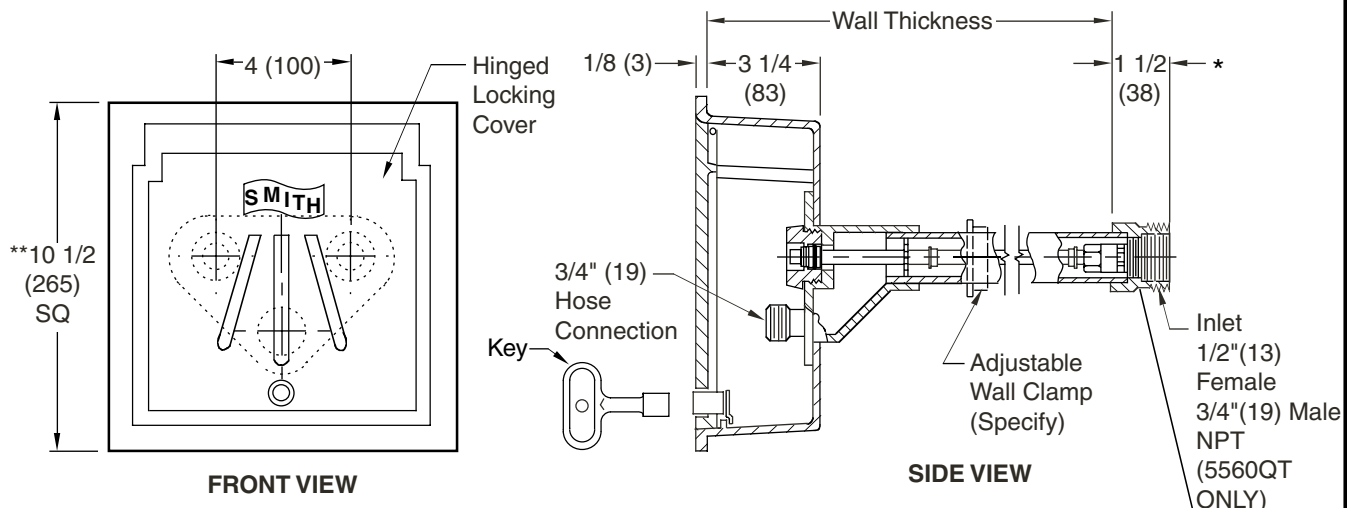

\*  Fig. 5560QT . . . . 1/2"(13) FEMALE & 3/4"(19) MALE INLET  
 Fig. 5561QT . . . . 1"(25) MALE NPT INLET

\* When specifying a 5561QT add 3/4"(19) to length of inlet connection as shown.

**REGULARLY FURNISHED:**

Bronze Nickel Plated Quarter Turn Non-Freeze "Twin-Temp" Hydrant with Hose Connection, "T" Handle Key, and Bronze Box with Chrome Plated Face, and Inlet Size Furnished as Indicated by Figure Number Selected.

**VARIATIONS:**

- Adjustable Wall Clamp -WC
- Cylinder Lock -CL
- 1" (25) Hose Connection -HC1
- 3/4"(19) Vacuum Breaker (Self Draining Type) -H
- "Water" Cast On Cover -W
- Wheel Handle -WH

**OPTIONAL MATERIALS:**

- Nickel Bronze Box -NB
- Polished Bronze Hydrant -PB
- Rough Bronze Box -RB

- NOTES:**
1. Recommended Wall Opening 9 3/4"(250) x 9 3/4"(250).\*\*
  2. When ordering, specify wall thickness in 2"(51) increments as follows: 6(150), 8(205), 10(255), 12(305), 14(355), 16(405), 18(455), 20(510), 22(560) or 24(610). When wall clamp -WC is desired, increase wall thickness dimension by 2"(51).
  3. For 6"(150) wall use 5560QT-SAP or 5561QT-SAP.
  4. All Jay R. Smith hydrants are manufactured with "NO-LEAD" brazing rings and USDA approved lubricants.
  5. When optional vacuum breaker is supplied hose must be removed to allow draining to prevent freezing.
  6. Dimensions shown in parentheses are in millimeters.

DRAWING NUMBER S5560QT  
 SIZE A  
 SCALE: NONE  
 DATE: 12-8-86  
 APPROVED BY: TD  
 CHECKED BY: VGD  
 DRAWN BY: WAS  
 5560QT, 5561QT  
 DIMENSIONS ARE SUBJECT TO MANUFACTURERS TOLERANCE AND CHANGE WITHOUT NOTICE  
 WE CAN ASSUME NO RESPONSIBILITY FOR USE OF SUPERSEDED OR VOID DATA

REV.	DATE	DESCRIPTION	BY	CKD. BY	WEIGHT POUNDS	VOLUME CUBIC FEET	FIGURE NUMBER
							<b>5560QT, 5561QT</b>

**PARTS LIST WITH MAINTENANCE INSTRUCTIONS**

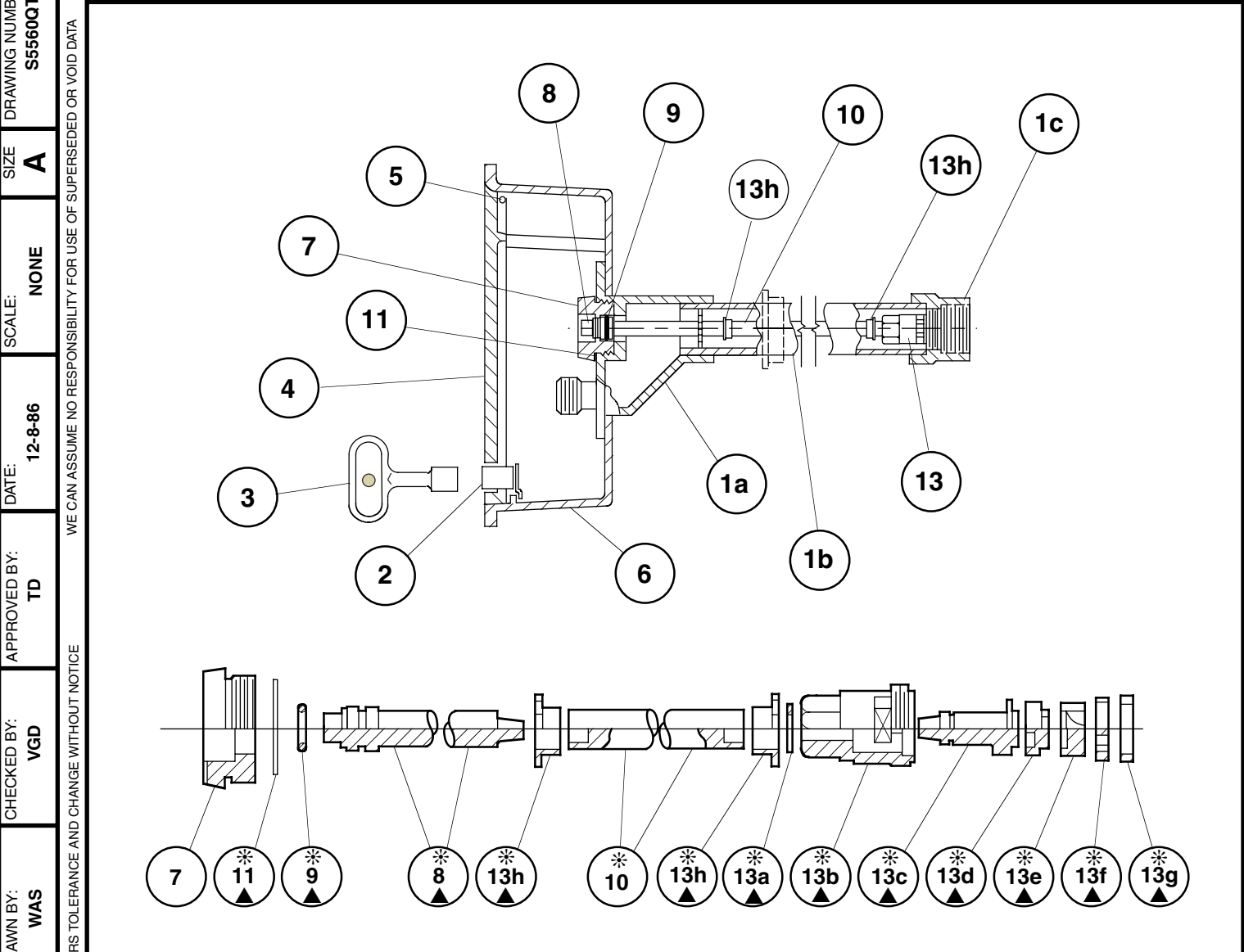

**HYDRANT PARTS LIST**

▲ These Replacement Parts Available in HPRK-7 (2) Repair Kits

\* These Parts Accessible from Face of Hydrant by Removing Face Nut.

NO.	DESCRIPTION	NO.	DESCRIPTION	NO.	DESCRIPTION
1	Head/Casing Assembly	6	Box	13b	Valve Body
1a	Head	7	Face Nut	13c	Valve Actuator
1b	Casing	8	Actuator Shaft	13d	Nylon Thrust Washer
1c	Valve Housing	9	Actuator "O" Ring	13e	Rotating Ceramic Disc
2	Locking Device	10	Operator Rod	13f	Fixed Ceramic Disc
3	Key	11	Face Nut Washer	13g	Silicon Rubber Seal
4	Cover	13	Valve Body Assembly	13h	Retainer Guide (2)
5	Hinge Pins (2)	13a	Retaining Ring		

FIGURE NUMBER	E D C	9-22-93	Chg'd Note Chg'd to QT Style Revised	EMB EMB WAS	BS TD	WEIGHT POUNDS	VOLUME CUBIC FEET	FIGURE NUMBER <b>5560QT, 5561QTBS</b>
		9-17-92						
REV.	DATE	DESCRIPTION	BY	CKD. BY				

DRAWING NUMBER: S5560QTBS  
 SIZE: A  
 SCALE: NONE  
 DATE: 12-8-86  
 APPROVED BY: TD  
 CHECKED BY: VGD  
 DRAWN BY: WAS

WE CAN ASSUME NO RESPONSIBILITY FOR USE OF SUPERSEDED OR VOID DATA

DIMENSIONS ARE SUBJECT TO MANUFACTURERS TOLERANCE AND CHANGE WITHOUT NOTICE