



JAY R. SMITH MFG. CO.
 DIVISION OF SMITH INDUSTRIES, INC.
 POST OFFICE BOX 3237
 MONTGOMERY, ALABAMA 36109-0237 (USA)
 TEL: 334-277-8520 FAX: 334-272-7396 www.jrsmith.com



LOCATION

LABOR SAVER® LAVATORY SUPPORTS WITH CONCEALED ARMS

FLOOR MOUNTED TYPE

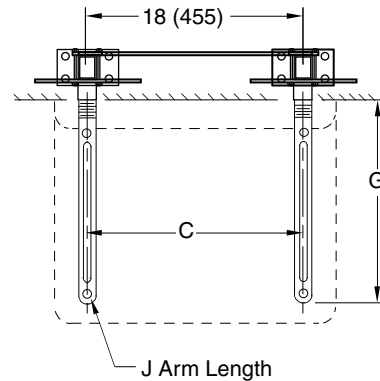
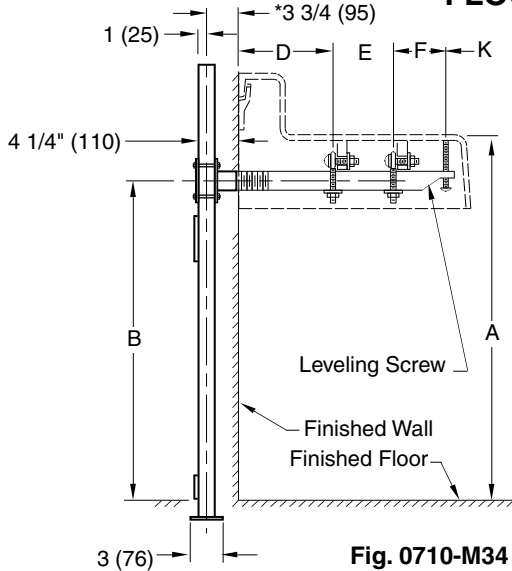
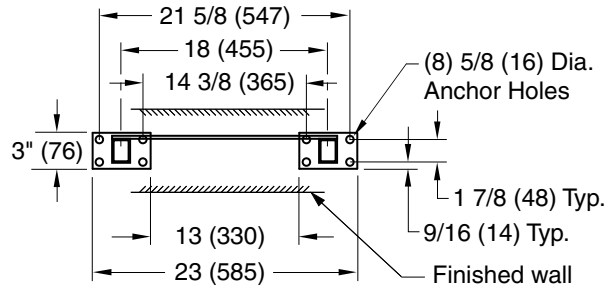

Fig. 0710-M34 ... FOR HIGH BACK LAVATORIES (shown)

NOTE: The rough-in dimensions listed on this drawing are based on current information available to Jay R. Smith by the fixture manufacturers. We recommend that you verify these dimensions with the fixture manufacturer. We will not accept responsibility for rough-in dimension changes by the fixture manufacturer.

NOTE: *This dimension includes a wall thickness of 1/2". For greater wall thickness, specify centerline of upright to finished wall dimension.

NOTE: Dimensions shown in parentheses are in millimeters.



BASE DETAIL

M-34 Finished Trim to be Furnished with each Support.

- (2) - 1/4 x 2 1/2 Round Head Screw
- (4) - 1/4 x 1 1/2 Round Head Screw
- (4) - 1/4 Eye Bolt x 2 1/2 Long
- (12) - 1/4 Steel Washer
- (8) - 1/4 Steel Nuts

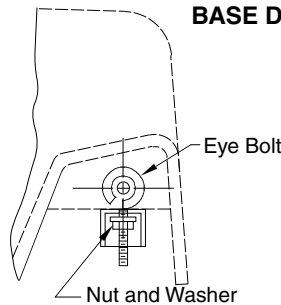
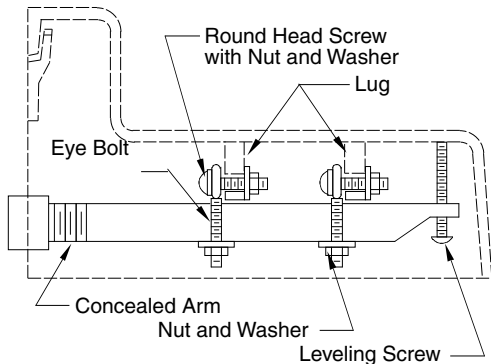

ROUGH-IN TABLE

FIXTURE MFG.		NAME		NUMBER		SIZE		
A	B	C	D	E	F	G	J	K

C	07/23/08	Revised Plate Configuration	JJ	CL
B	8-30-04	Revised "A" Dimension	TBW	CL
A	12/06/02	Revised per George Flegel	JJ	AM
REV.	DATE	DESCRIPTION	BY	CKD. BY

WEIGHT POUNDS	VOLUME CUBIC FEET	FIGURE NUMBER
		0710-M34

DRAWING NUMBER
S0710-M34

SIZE
A

SCALE:
NONE

DATE:
06/10/02

APPROVED BY:
AM

CHECKED BY:
CR

DRAWN BY:
JJ

0710-M34

FIGURE NUMBER

DIMENSIONS ARE SUBJECT TO MANUFACTURERS TOLERANCE AND CHANGE WITHOUT NOTICE

WE CAN ASSUME NO RESPONSIBILITY FOR USE OF SUPERSEDED OR VOID DATA