



LOCATION

LABOR SAVER LAVATORY SUPPORTS

FLOOR MOUNTED TYPE WITH CONCEALED ARMS FOR NARROW WALL INSTALLATION

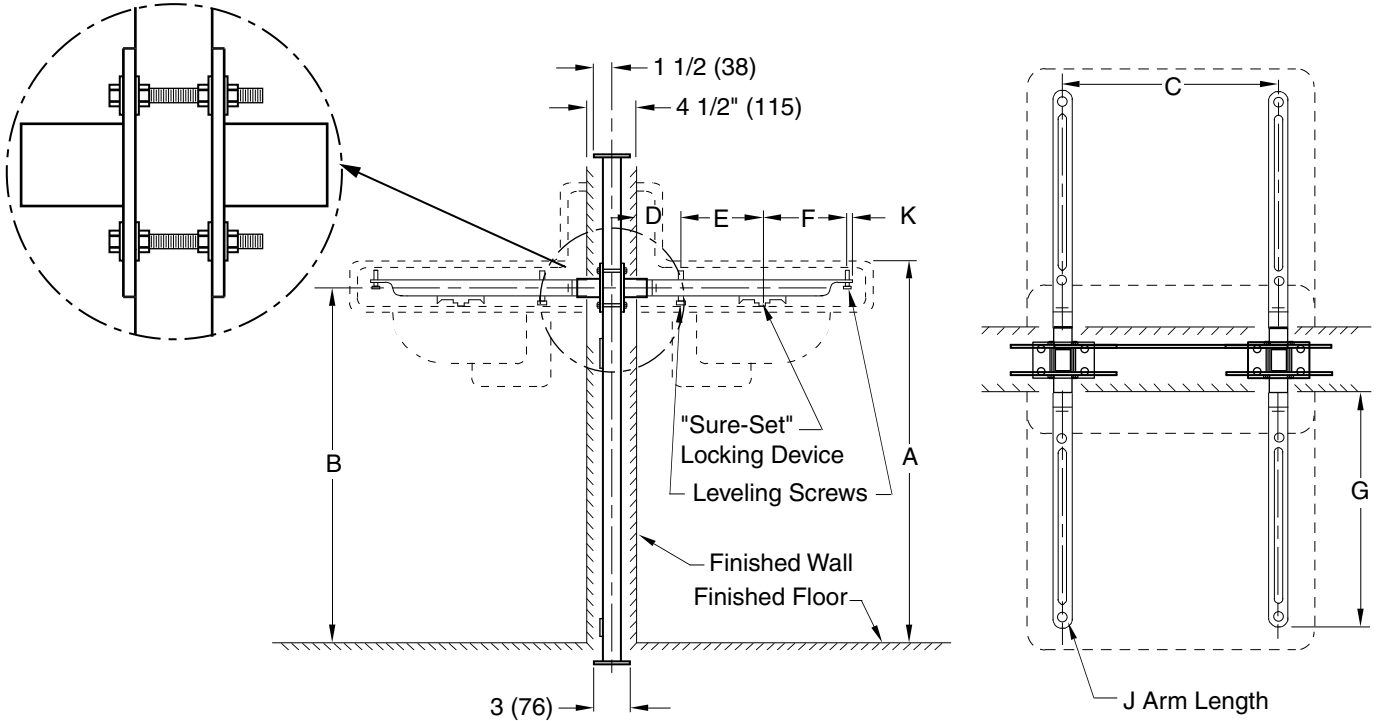
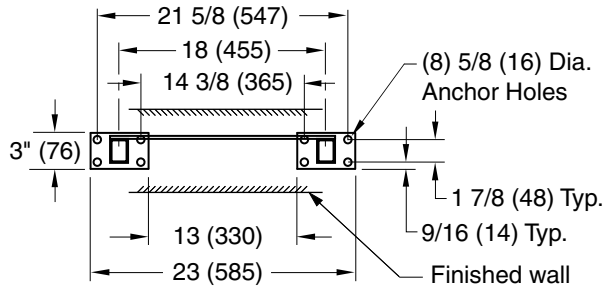

Fig. 0710DZ.....FOR BACK TO BACK SUPPORT

NOTE: The rough-in dimensions listed on this drawing are based on current information available to Jay R. Smith by the fixture manufacturers. We recommend that you verify these dimensions with the fixture manufacturer. We will not accept responsibility for rough-in dimension changes by the fixture manufacturer.

NOTE: Dimensions shown in parentheses are in millimeters.



BASE DETAIL

ROUGH-IN TABLE

FIXTURE MFG.		NAME		NUMBER		SIZE		
A	B	C	D	E	F	G	J	K

DRAWING NUMBER
S0710DZ

SIZE
A

SCALE:
NONE

DATE:
07/09/03

APPROVED BY:
CL

CHECKED BY:
CL

DRAWN BY:
JJ

FIGURE NUMBER
0710DZ

WE CAN ASSUME NO RESPONSIBILITY FOR USE OF SUPERSEDED OR VOID DATA

DIMENSIONS ARE SUBJECT TO MANUFACTURERS TOLERANCE AND CHANGE WITHOUT NOTICE

A	11/17/08	Revised Plate Configuration	JJ	CL
REV.	DATE	DESCRIPTION	BY	CKD. BY

WEIGHT POUNDS
VOLUME CUBIC FEET

FIGURE NUMBER
0710DZ