

C

SMITH® JAY R. SMITH MFG. CO.®
 DIVISION OF SMITH INDUSTRIES, INC.
 POST OFFICE BOX 3237
 MONTGOMERY, ALABAMA 36109-0237 (USA)
 TEL: 334-277-8520 FAX: 334-272-7396 www.jrsmith.com



LOCATION

LABOR SAVER™ LAVATORY SUPPORTS

FLOOR MOUNTED TYPE WITH EXPOSED ARMS

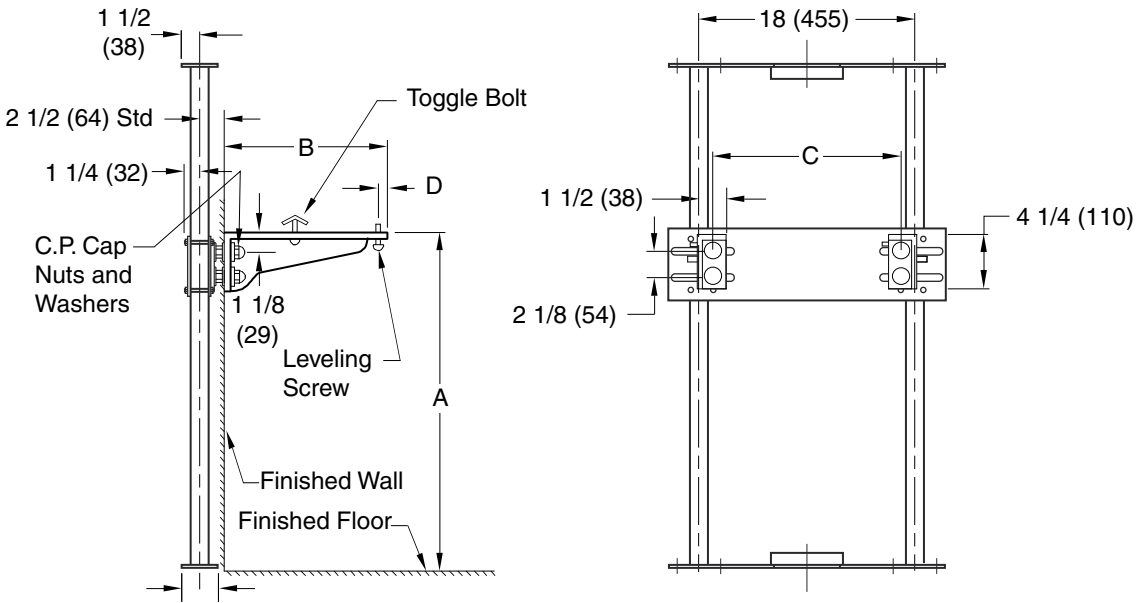
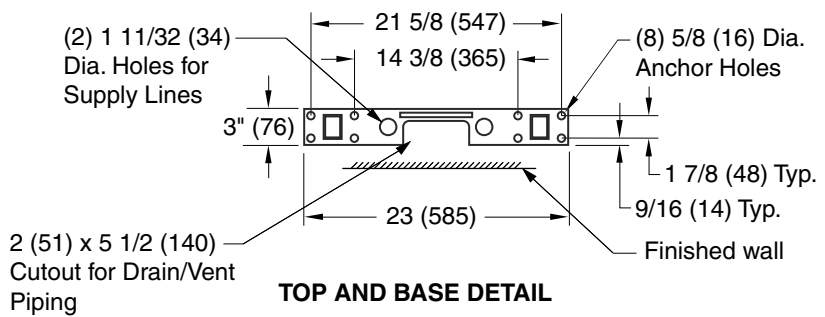

Fig. 0760 . . . WITH ACID RESISTANT COATED EXPOSED ARMS FOR FLAT SLAB AND HIGH BACK LAVATORIES.

NOTE: The rough-in dimensions listed on this drawing are based on current information available to Jay R. Smith by the fixture manufacturers. We recommend that you verify these dimensions with the fixture manufacturer. We will not accept responsibility for rough-in dimension changes by the fixture manufacturer.

NOTE: *This dimension can be increased when fixture support is to be installed behind the wall. (Specify when required and wall thickness).

NOTE: Dimensions shown in parenthesis are in millimeters.



ROUGH-IN TABLE

FIXTURE MFG.	NAME	NUMBER	SIZE	A	B	C	D

DRAWING NUMBER
S0760

SIZE
A

SCALE:
NONE

DATE:
04/04/01

APPROVED BY:
AM

CHECKED BY:
CR

DRAWN BY:
JJ

0760

WE CAN ASSUME NO RESPONSIBILITY FOR USE OF SUPERSEDED OR VOID DATA

DIMENSIONS ARE SUBJECT TO MANUFACTURERS TOLERANCE AND CHANGE WITHOUT NOTICE

REV.	DATE	DESCRIPTION	BY	CKD. BY
C	11/07/02	Changed per George Flegel	JJ	AM
B	12/19/01	Changed Hole Size in Base	JJ	AM
A	11/06/01	Inside wall (washer/nut/washer)	JJ	AM

WEIGHT
POUNDS

VOLUME
CUBIC FEET

FIGURE NUMBER
0760