

A



JAY R. SMITH MFG. CO.®
 DIVISION OF SMITH INDUSTRIES, INC.
 POST OFFICE BOX 3237
 MONTGOMERY, ALABAMA 36109-0237 (USA)
 TEL: 334-277-8520 FAX: 334-272-7396 www.jrsmith.com



LOCATION

FIXTURE SUPPORT FLOOR MOUNTED

WITH SUPPORTING PLATES AND STUDS

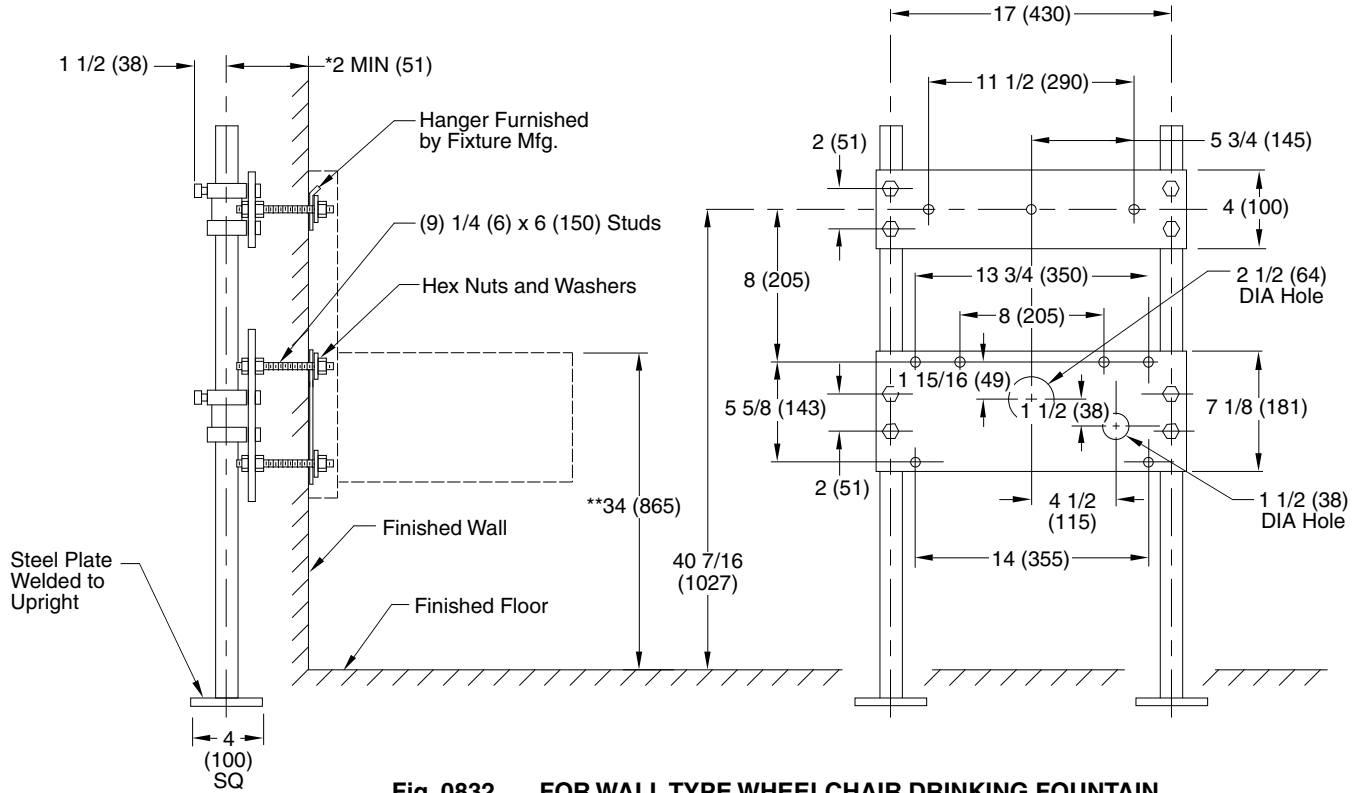
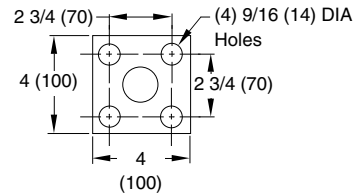

Fig. 0832 . . . FOR WALL TYPE WHEELCHAIR DRINKING FOUNTAIN

MFGR. ELKAY MODEL EDFP - 14
 Furnished with 48" (1220) Uprights

NOTES:

- *This dimension includes wall thickness of 1/2" (13). For greater wall thickness, specify centerline of upright to finished wall dimension.
- **Check local codes for exact height



BASE DETAIL

NOTE: The rough-in dimensions listed on this drawing are based on current information available to Jay R. Smith by the fixture manufacturers. We recommend that you verify these dimensions with the fixture manufacturer. We will not accept responsibility for rough-in dimension changes by the fixture manufacturer.

NOTE: Dimensions shown in parenthesis are in millimeters.

DRAWING NUMBER
S0832

SIZE
A

SCALE:
NONE

DATE:
6-9-83

APPROVED BY:
TD

CHECKED BY:
TD

DRAWN BY:
CR

0832

WE CAN ASSUME NO RESPONSIBILITY FOR USE OF SUPERSEDED OR VOID DATA

DIMENSIONS ARE SUBJECT TO MANUFACTURERS TOLERANCE AND CHANGE WITHOUT NOTICE

A	4-10-95	Submittal Update	EMB	
REV.	DATE	DESCRIPTION	BY	CKD. BY

WEIGHT POUNDS	VOLUME CUBIC FEET

FIGURE NUMBER 0832
