

FIXTURE SUPPORT FLOOR MOUNTED

WITH HANGER AND BRACKET SUPPORT PLATED

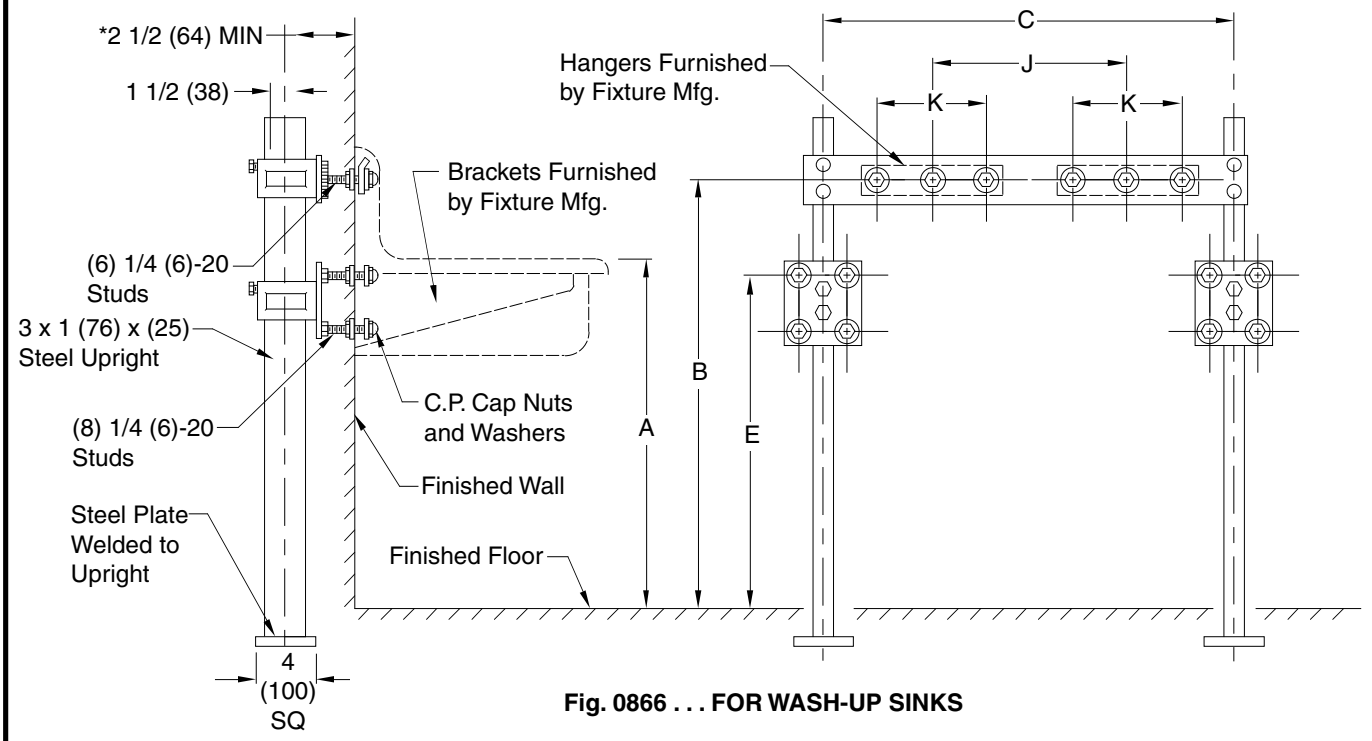
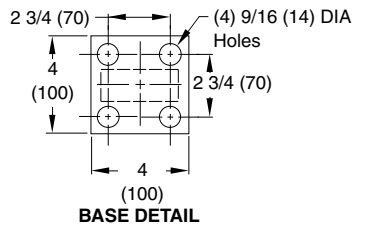

Fig. 0866 . . . FOR WASH-UP SINKS

NOTE: The rough-in dimensions listed on this drawing are based on current information available to Jay R. Smith by the fixture manufacturers. We recommend that you verify these dimensions with the fixture manufacturer. We will not accept responsibility for rough-in dimension changes by the fixture manufacturer.

NOTE: Dimensions shown in parenthesis are in millimeters.

*This dimension includes wall thickness of 1/2" (13) for greater wall thickness, specify centerline of upright to finished wall dimension.



MANUFACTURER	NUMBER	SIZE	A	B	C	E	J	K

DRAWING NUMBER: **S0866 (-M31) (B)**
 SIZE: **A**
 SCALE: **NONE**
 DATE: **2-26-86**
 APPROVED BY: **TD**
 CHECKED BY: **CR**
 DRAWN BY: **TD**
0866 (-M31)
 DIMENSIONS ARE SUBJECT TO MANUFACTURERS TOLERANCE AND CHANGE WITHOUT NOTICE

A	4-25-95	Submittal Update	EMB		WEIGHT POUNDS	VOLUME CUBIC FEET	FIGURE NUMBER
REV.	DATE	DESCRIPTION	BY	CKD. BY			0866 (-M31)