

HEAVY DUTY SINK SUPPORTS

FLOOR MOUNTED WITH ACID RESISTANT COATED EXPOSED ARMS & "PRO-SET" UPRIGHTS

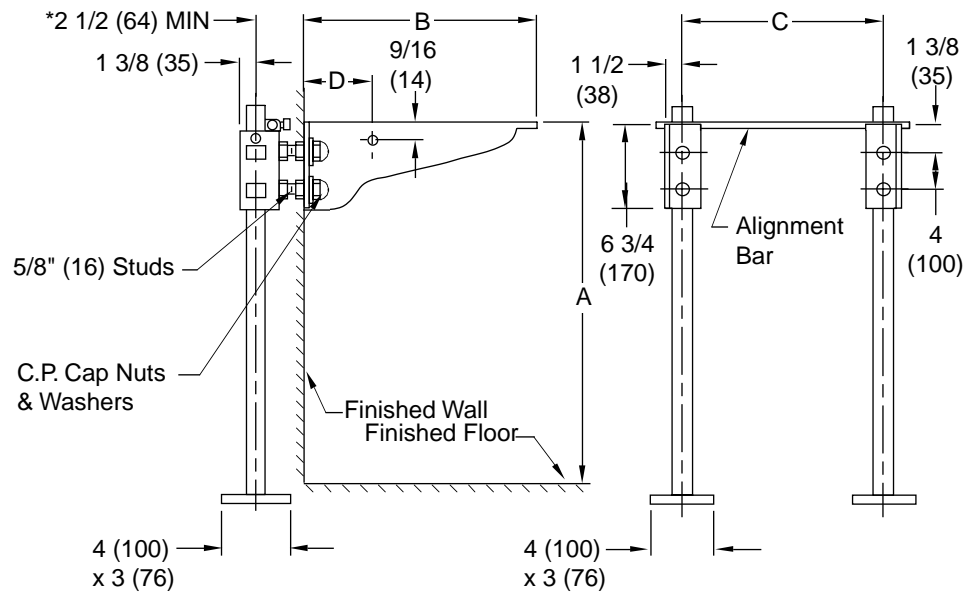
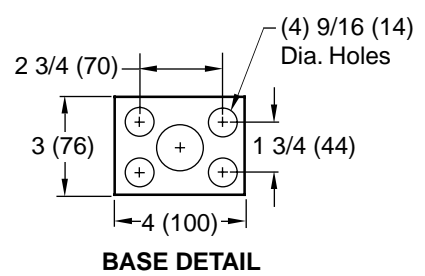

Fig. 0871 . . . WITH OFFSET ARMS FOR ENAMELED IRON SERVICE SINKS WITH CAST LUGS UNDER BASIN

*This dimension can be increased when fixture support is to be installed behind the wall (specify when required and wall thickness).

NOTE: For extra heavy duty support with 1 1/2 (38) pipe uprights, add Suffix "X" to Fig. No.

NOTE: Dimensions shown in parentheses are in millimeters.



ROUGHING-IN TABLE

FIXTURE NAME	NUMBER	SIZE	A	B	C	D

NOTE: The rough-in dimensions listed on this drawing are based on current information available to Jay R. Smith by the fixture manufacturers. We recommend that you verify these dimensions with the fixture manufacturer. We will not accept responsibility for rough-in dimension changes by the fixture manufacturer.

DRAWING NUMBER S0871 (B) SIZE A SCALE: NONE DATE: 10-30-63 APPROVED BY: RP CHECKED BY: SL DRAWN BY: SL FIGURE NUMBER 0871

WE CAN ASSUME NO RESPONSIBILITY FOR USE OF SUPERSEDED OR VOID DATA DIMENSIONS ARE SUBJECT TO MANUFACTURERS TOLERANCE AND CHANGE WITHOUT NOTICE

E D C	01/19/00 6-12-95 8-18-93	Revised Base Plate Added Millimeters Submittal Update	JJ EMB EMB	BS BS	WEIGHT POUNDS	VOLUME CUBIC FEET	FIGURE NUMBER 0871
REV.	DATE	DESCRIPTION	BY	CKD. BY			