

LABOR SAVER HEAVY DUTY FIXTURE SUPPORT

FLOOR MOUNTED FOR SURGICAL SCRUB UP & FLUSHING RIM SINK

DRAWING NUMBER: **S0923, 0924 (-KW)**
 SIZE: **A**
 SCALE: **NONE**
 DATE: **05/28/02**
 APPROVED BY:
 CHECKED BY:
 DRAWN BY: **JJ**
0923, 0924 (-KW)
 DIMENSIONS ARE SUBJECT TO MANUFACTURER'S TOLERANCE AND CHANGE WITHOUT NOTICE

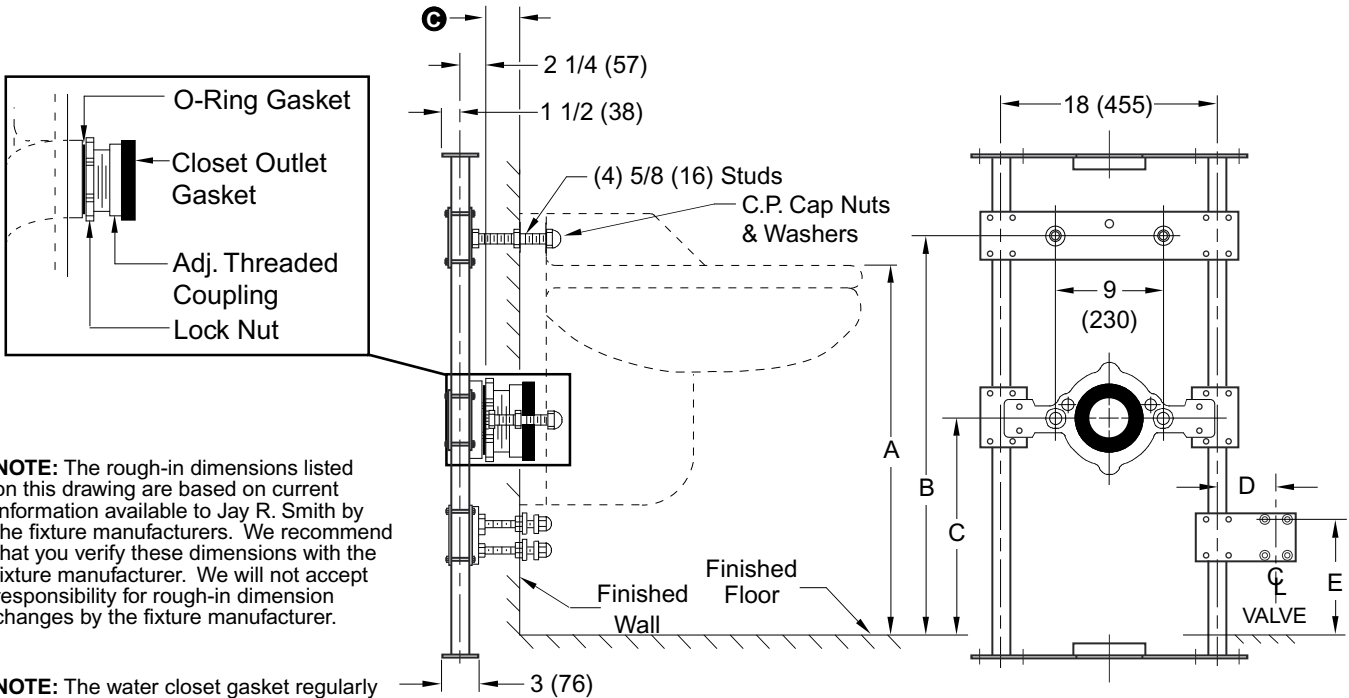

NOTE: The rough-in dimensions listed on this drawing are based on current information available to Jay R. Smith by the fixture manufacturers. We recommend that you verify these dimensions with the fixture manufacturer. We will not accept responsibility for rough-in dimension changes by the fixture manufacturer.

NOTE: The water closet gasket regularly furnished is made of molded neoprene and designed to fit water closet outlet dimensions and configurations shown in ANSI Standard A112.19.2M-1982, Figure 13B. If gasket is not found to be compatible to fixture due to nonconformance of said fixture to ANSI A112.19.2M, then fixture manufacturer shall be consulted for a suitable gasket recommendation. Jay R. Smith assumes no liability for connections to fixtures which do not conform to these standards.

NOTE: Dimensions shown in parenthesis are in millimeters.

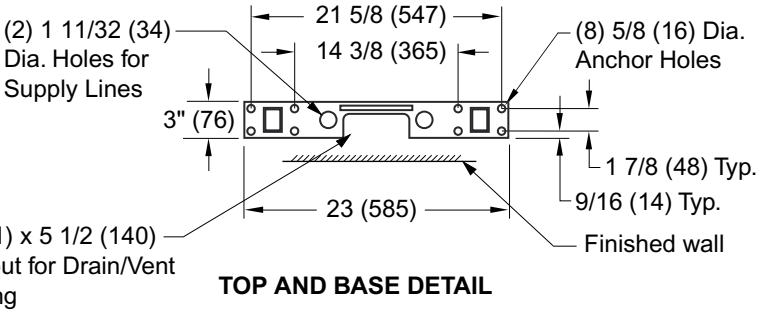

Fig. 0923..... 3" (80) OUTLET CONNECTION
Fig. 0924..... 4" (100) OUTLET CONNECTION
Fig. 0923 & 0924... WITH SUPPORTING STUD AND ADJUSTABLE COUPLING FOR BACK OUTLET FLUSHING RIM SERVICE SINK

| FIG | SIZE | ⊙ MIN | ⊙ MAX |
|------|----------|------------|-------------|
| 0923 | 3" (80) | 2 3/4 (70) | 4 3/4 (120) |
| 0924 | 4" (100) | 1 (25) | 3 (76) |

ROUGH-IN TABLE

| FIXTURE MFG. | NAME | NUMBER | SIZE | A | B | C | D | E |
|--------------|------|--------|------|---|---|---|---|---|
| | | | | | | | | |

⊙ This Dimension Can be Increased When Fixture Support is to be Installed Behind the Wall (Specify When Required and Wall Thickness).

| | | | | | | | |
|------|------|-------------|----|---------|---------------|-------------------|-------------------------|
| REV. | DATE | DESCRIPTION | BY | CKD. BY | WEIGHT POUNDS | VOLUME CUBIC FEET | FIGURE NUMBER |
| | | | | | | | 0923, 0924 (-KW) |