

HYDRANTS

SMITH®

FIG. 5810 SER. BRONZE NON-FREEZE GROUND HYDRANT W/ROUGH BRONZE BOX AND BRONZE CASING



FUNCTION: A Hydrant with a hinged covered box, for positive protection against freezing when buried outside or in unheated areas and the closing valve is located below the frost line. When hydrant is shut off, water is drained from the casing through the drain hole in the valve housing. The locking cover prevents unauthorized use.

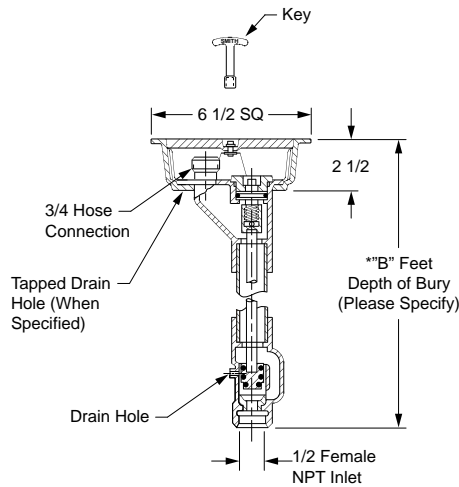

Side View

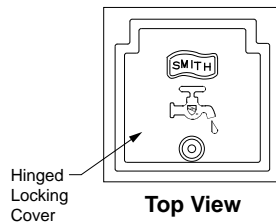

Top View

Fig. 5810

OPTIONS:

-CL	Cylinder Lock	117.00
-CP	Chrome Plated Box	190.00
-H	3/4" Vacuum Breaker	N/C
-HC1	1" Hose Conn Adaptor	133.00
-LD	Less Drain Hole	N/C
-N	1/8" NPT Drain Hole in Box	117.00
-NB	Nickel Bronze Box.....	173.00
-NV	1/8" NPT Drain Hole in Housing	N/C
-PB	Polished Bronze Box.....	38.00
-W	"Water" on Cover	N/C

ADD

For Hydrant Parts Repair Kit, See Pg. 340

NOTES:

1. Recommended Box-out 5 3/4 x 5 3/4".
2. All Jay R. Smith hydrants are manufactured with "NO-LEAD" brazing rings and USDA approved lubricants.

Addition of vacuum breaker will not allow draining of the casing. Smith is not responsible for any casings that burst or related incidents if the hydrant is supplied with a vacuum breaker.

*B = 9 1/2" when specified (-SAP)

B FEET DEPTH OF BURY	5810 3/4" INLET	5811 1" INLET	APPROX WEIGHT LBS
-SAP	1,261.00	1,521.00	8
02'	1,261.00	1,521.00	17
03'	1,360.00	1,620.00	21
04'	1,460.00	1,719.00	25
05'	1,559.00	1,818.00	33
06'	1,658.00	1,916.00	39
07'	1,756.00	2,015.00	45
08'	1,855.00	2,115.00	52
09'	1,954.00	2,213.00	54
10'	2,054.00	2,312.00	56

REGULARLY FURNISHED: Bronze Non-Freeze Ground Hydrant with "T" Handle Key and Bronze Hydrant Box. Inlet Size Furnished as Indicated by Figure Number Selected.

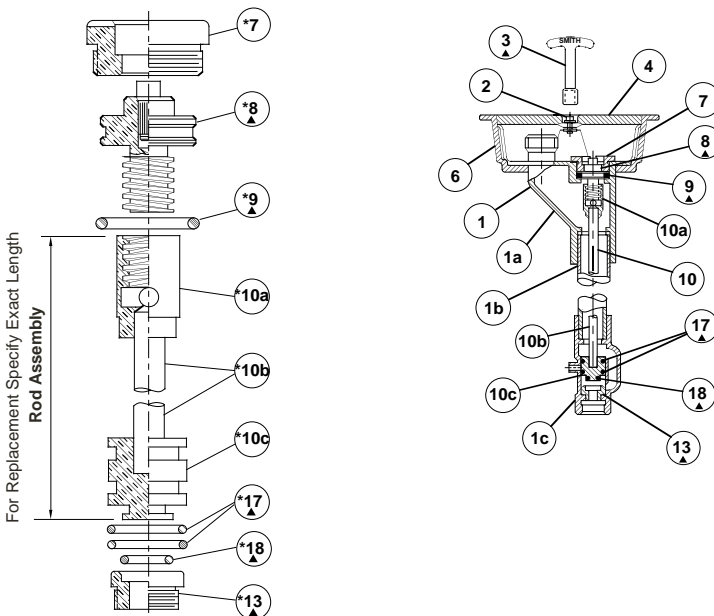

REPLACEMENT PARTS - SPECIFY FIG. NO. WHEN ORDERING

No.	DESCRIPTION	No.	DESCRIPTION
1	Head/Casing Assembly	8	Operating Screw
1a	Head	9	Operating Screw "O" Ring
1b	Casing	10	Operating Rod Assembly
1c	Valve Housing	10a	Coupling
2	Locking Device	10b	Rod
3	Key	10c	Plunger
4	Cover	13	Removable Seat
5	Hydrant Cover Hinge Pins (2)	17	Plunger "O" Ring
6	Box	18	Plunger "O" Ring
7	Face Nut		

- ▲ These Replacement Parts Available in HPRK-41
- * These parts are accessible from face of hydrant by removing face nut.

MAINTENANCE INSTRUCTIONS

1. Shut off water supply.
2. Remove face nut.
3. Pull stem out for complete access to all working parts.
4. Check all working parts for replacement.
5. Replace complete stem assembly and face nut.

HYDRANTS