

INTERCEPTORS

FIG. 8510, 8510E SERIES STEEL OIL INTERCEPTORS



FUNCTION: Fig. 8510, Used in service stations, parking garages, and industrial plants where discharged water contains oil and sediment. Interceptor collects oil and conveniently permits the collected oil to be drained to a storage tank by means of an adjustable gravity draw-off connection. Sediment and chips are collected in sediment bucket and should be periodically removed. Interceptors should not be located directly in traffic areas. If required, specify extra heavy duty traffic cover.

Fig. 8510E, Interceptors with extensions are installed recessed in the floor with cover flush with finished floor. Extension provides additional roughing depth from top of interceptor to centerline of inlet and outlet. Extension should not be used as a means for supporting the assembly. The entire interceptor body and extension must rest on solid ground or suitable support hangers.

OPTIONS:

- Y No-Hub Adaptor (4 req'd) See Fig. 2646Y
- *Inlet & Outlet, One Size Larger /N/C

ADD

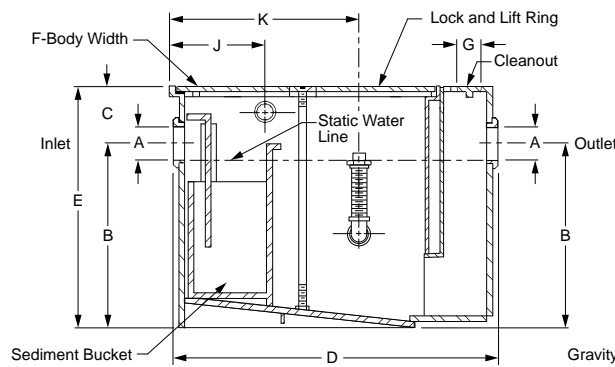

Side View

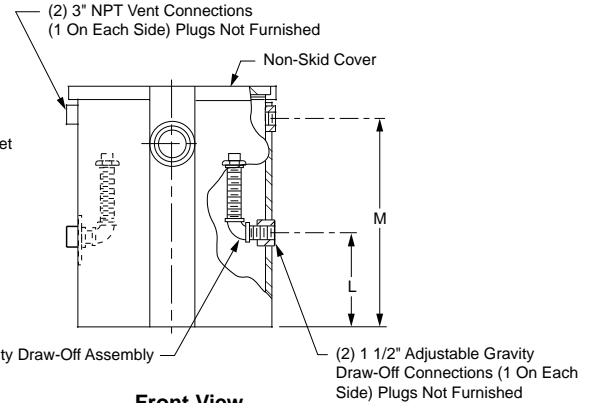

Front View

Fig. 8510 Shown

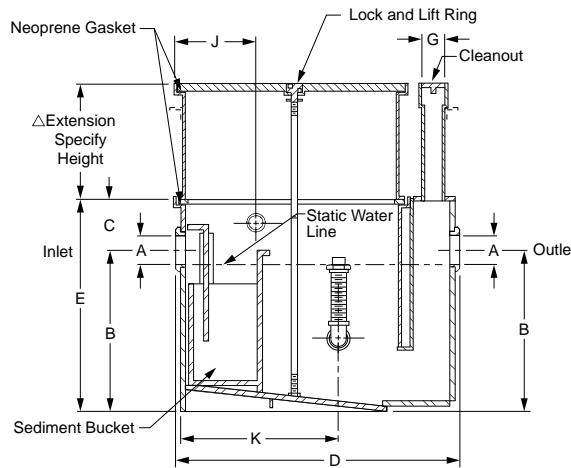

Side View

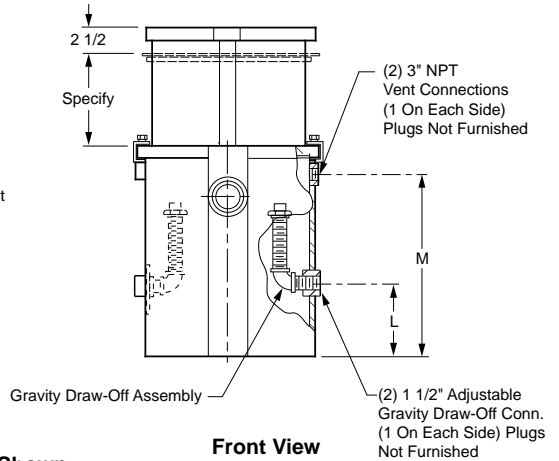

Front View

Fig. 8510E Shown

FIG. NO.	GPM FLOW RATE	INLET & OUTLET SIZE A	ROUGHING DIM			BODY		C.O. PLUG SIZE G	J	K	L	M	†STEEL DUCO COATED	INTERC. Δ WITH 4 TO 6" EXT (-E) DUCO COATED	ADD FOR:					APPROX. WT. LBS.
			B	C	D	E HEIGHT	F WIDTH								EA 1" EXT OVER 6"	ANCHOR FLANGE (-F) (W/EXT ONLY)	FLANGE AND FLASH CLAMP (-FC) (W/EXT ONLY)	H2O COVER	ALUM COVER (-AC)	
8510	10	02"	9 1/2"	3 3/4"	21 1/4"	13 1/4"	11 1/2"	2"	9 1/2"	12"	4"	9 3/4"	3,794.00	6,665.00	143.00	895.00	1,078.00	3,737.00	850.00	100
8515	15	*02"	12"	3 1/2"	25"	15 1/2"	13 1/2"	2"	10 1/4"	14 1/4"	5 3/4"	12"	5,034.00	7,988.00	161.00	895.00	1,078.00	4,019.00	850.00	110
8520	20	*03"	13"	4"	28 1/2"	17"	15 3/4"	2"	12"	16 1/2"	4 1/2"	13 1/2"	5,914.00	8,868.00	182.00	968.00	1,150.00	4,255.00	1,190.00	125
8525	25	*03"	15 1/4"	4 1/2"	30"	19 3/4"	16 3/4"	2"	12 3/4"	18 3/4"	6 1/4"	16 1/4"	6,557.00	9,704.00	207.00	1,007.00	1,202.00	4,492.00	1,190.00	145
8535	35	*03"	16"	5"	32 1/2"	21"	18 1/4"	2"	14 1/2"	21 1/4"	7"	17 1/2"	7,876.00	11,404.00	227.00	1,056.00	1,252.00	4,964.00	1,190.00	175
8550	50	*03"	17 1/2"	6 3/4"	35 1/2"	24 1/4"	20 3/4"	2"	16"	22"	7 1/2"	20 3/4"	10,619.00	14,433.00	264.00	1,078.00	1,418.00	5,200.00	1,190.00	215

*Available with larger inlet and outlet when specified.

Δ Specify Extension Height when ordering, measuring from top of interceptor to top of extension.

REGULARLY FURNISHED: Fig. 8510, Steel Interceptor with Gray Duco Coating Inside and Outside and Flow Control Fitting.

Fig. 8510E, Steel Interceptor and Extension with Gray Duco Coating Inside and Outside and Flow Control Fitting.

INTERCEPTORS