

ROOF DRAINS

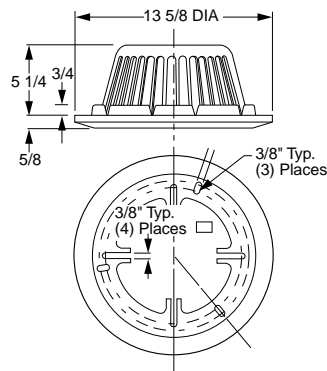

FIG. 1001 UNIVERSAL REPLACEMENT DOME AND COLLAR ASSEMBLY

FUNCTION: Universal cast iron membrane clamping collar and dome are designed for retrofit roof applications where the existing main roof drain body is to remain in place and continue to be operative. The bolting lugs of this collar match the bolt pattern of the majority of the common roof drain bodies and generally conform to the surface angles of the flange. This allows easy replacement along with adequate pressure on the membrane to insure water tightness. The collar is designed to accompany most 15" and 16" diameter roof drain bodies with bolt circles ranging 7 1/4" to 10 3/4" in diameter. It is recommended to extend roof membrane into the sump of existing roof drain body.



OPTIONS:

	ADD
-AD	Aluminum DomePOA
-CID	Cast Iron DomePOA
-CID8	8" High Cast Iron Dome.....POA
-CIDG	Galvanized Cast Iron Dome (add to -CID)POA
-G	Galvanized CollarPOA
-LD	Less Dome(Specify Fig. 1002)
	Perforated Stainless Steel Gravel Guard (Specify Height)POA
-RBD	Rough Bronze DomePOA
-SSM	Stainless Steel Mesh Covered Dome (Specify Dome)POA
	Solid Water Dam Collar (Specify Height)POA
-U	Vandal ProofPOA

COLLAR DIA.	FREE AREA SQ IN	†DUCO CI COLLAR POLY DOME	APPROX. WEIGHT LBS
13 5/8"	102.5	POA	14.72

REGULARLY FURNISHED:

Polyethylene "Twist Lock" Dome and Duco Coated Universal Cast Iron Membrane Clamping Collar with Mounting Hardware.

ROOF DRAINS

FIG. 1005 SIPHONIC ROOF DRAIN 15 1/4" DIAMETER - LOW PROFILE DOME

FUNCTION: For use in engineered siphonic roof drainage system. May be used in flat roof of any construction. Large low profile dome provides sufficient free area for quick drainage of rain water and protects the drain sump, baffle and connected piping from the intrusion of debris. Internal air baffle creates siphonic drainage action producing more efficient drainage than traditional roof drains.

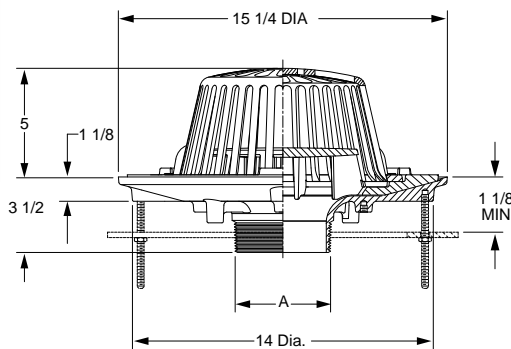

OUTLET VARIATIONS (Specify type of outlet and pipe size in inches.)

Outlet Type	Outlet Designation	Outlet Type/Pipe Size	Body HT. DIM.	ADD
Male Threaded Outlet	T02, *T0250, T03, T04		3 1/2"	POA
No-Hub	Y02, Y03, Y04		3 1/2"	POA

*2 1/2" pipe size only available with male threaded outlet

OPTIONS:

	ADD
-AD	Aluminum DomePOA
-C	Underdeck ClampPOA
-C10	Underdeck Clamp for 10" Deck OpeningPOA
-CID	CI Dome.....POA
-CIDG	Galv. Cast Iron Dome (add to -CID)POA
-CL	"L" Shaped Underdeck ClampPOA
-G	Galvanized CIPOA
-R	Sump ReceiverPOA
-RBD	Rough Bronze DomePOA
-U	Vandal Proof ScrewsPOA

A OUTLET SIZE	FLANGE DIA.	FREE AREA SQ IN	†DUCO CI POLY DOME	APPROX. WEIGHT LBS
02, *0250"	15 1/4"	102.5	POA	39
03, 04"	15 1/4"	102.5	POA	39

REGULARLY FURNISHED: Duco Cast Iron Body, Flashing Clamp, Air Baffle and Polyethylene Dome.