

# RAINWATER HARVESTING INSTALLATION GUIDE RH9508, RH9510, RH9511

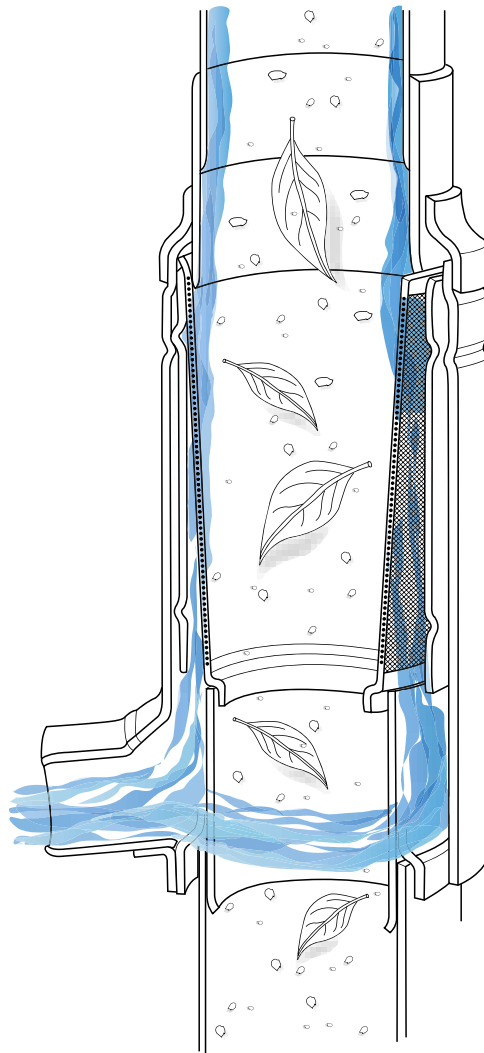

Please read these instructions carefully before installing the Filter Collector.

# RH9508 (WISY GRS 100) RH9510 (WISY FS) Instructions for installation and use

## Area of application

The Filter Collectors are designed to be inserted directly into the vertical section of rainwater pipe.

## Construction and Mode of Operation

- The Filter Collector filters the roof run-off water directly in the rainwater downpipe and then passes the filtered water through the outlet connection to the storage tank. The special construction of the filter is designed to separate coarse materials like leaves, moss, insects, etc. as well as fine pollutants which are washed through the downpipe to the storm drain.

- With a mesh size of 0.28 mm, the unit can supply water suitable for washing machines, water closets, urinals, etc.

- The construction of the Filter Collector unit does not create any obstruction or narrowing of the downpipe. The Gentle Gravity Filtering technology (Euro patent) ensures that the full flow of the rainwater in the downpipe and through the filter is maintained.

- The compact type of construction and the small dimensions allow for simple installation to almost any downpipe.

### Please note:

The most ideal collecting surfaces are pitched roofs of shingle, tile or slate. Turf roofs are less suitable due to their low water yield. Asbestos or heavily soiled roofs should not be used. A standard shingled roof should be allowed to weather for 6 months prior to installing a filter.

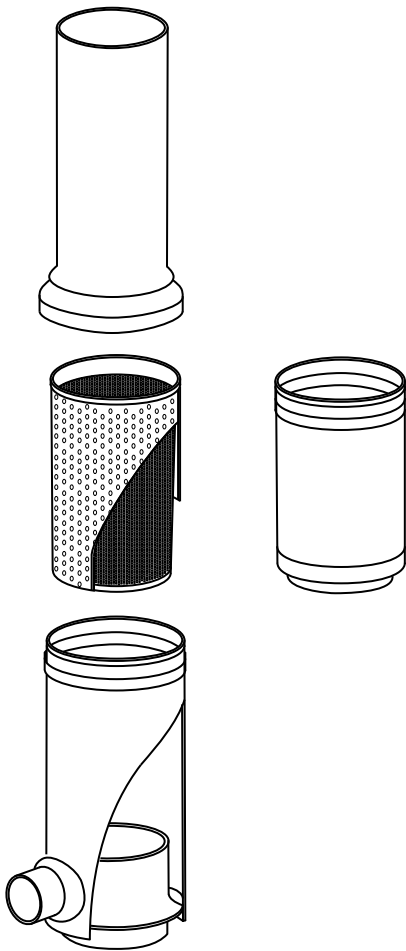

## Installation

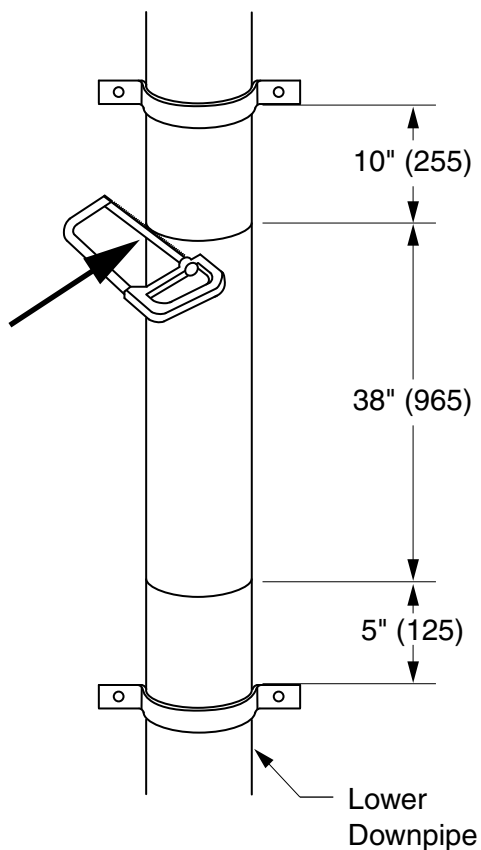

- For the RH9510 model, remove a 38" (965) section of gutter downpipe at the desired installation height. Install rectangular adaptor and clamp new 4" round pipe to the wall 10" from the outlet end.

- Slide the upper housing onto the lower portion of the downspout converter.

- Locate the lower housing and attach to lower downpipe, using an adaptor if required. Lower pipe and lower housing must be secured to wall. Use included clip (RH 9510SC) to mount housing and ensure that the filter is perfectly leveled.

- Slide down the upper housing to lock the filter in position.

- Connect the outlet connection to the storage tank with the RH9510TH Flexible hose. PVC pipe can be attached to the RH9510TH and routed to the storage tank.

NOTE: Filter collector must be mounted plumb for proper operation.

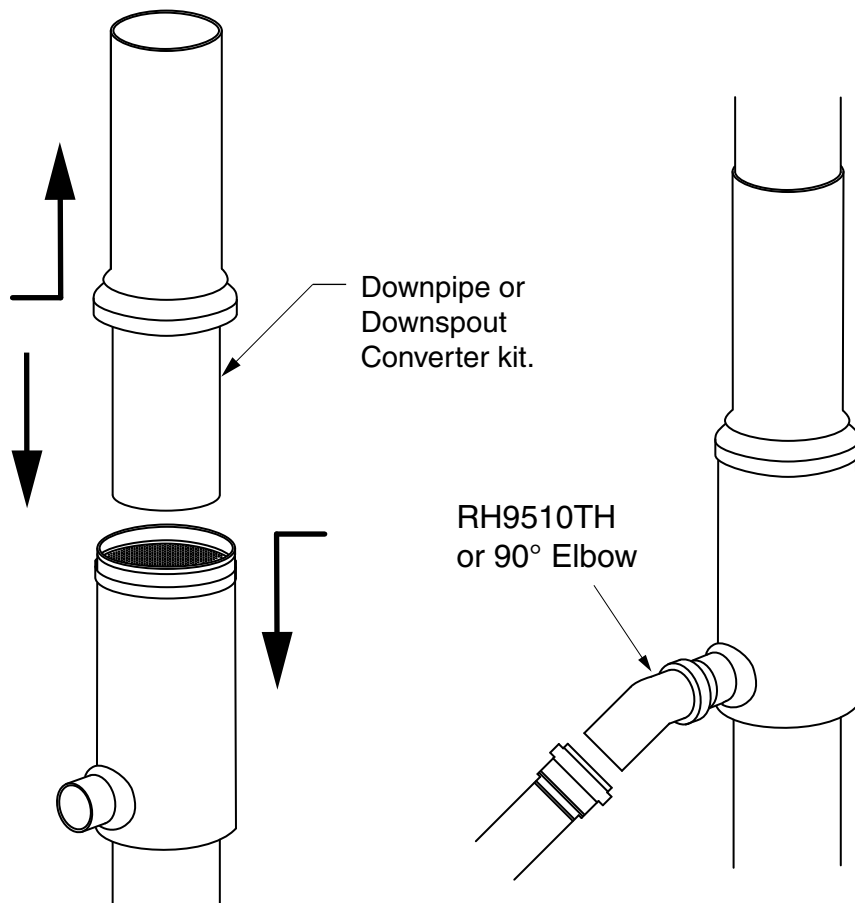

Please read these instructions carefully before installing the Filter Collector.

# RH9511 (WISY STFS)

## Standpipe Filter Collector

### Instructions for installation and use

- Standpipe Filter Collectors accept 4" sewer and drainpipe. For use with rectangular-shaped gutter, the RH9510DK Converter Kit can be utilized. For other cases, we recommend adjusting the rainwater downpipes to the sizes of a standard filter collector.

- Installations must include a straight section of downpipe before the filter for maximum efficiency. The use of the Converter Kit (RH9510DK) will satisfy this requirement.

- Pitched roofs shingles, slate, clay or concrete tiles are most suitable for collecting the rainwater. Planted roof areas are less suitable because of the low water collection efficiency and the brown color imparted into the collected water. Non-sealed asbestos cement roofs are less suitable. The fibers of this roof covering tend to block the fine filter mesh.

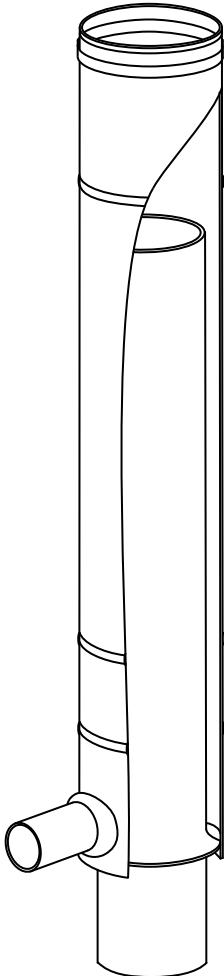
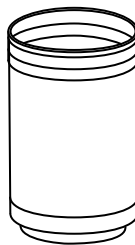
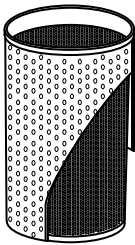
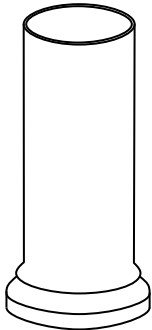

### **Construction and Mode of Operation**

- See instructions for RH9510 on page 1.

RH9510DK  
Converter Kit

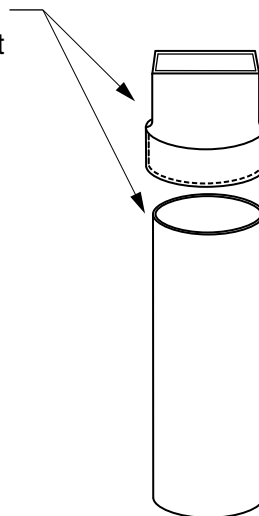

## Assembly

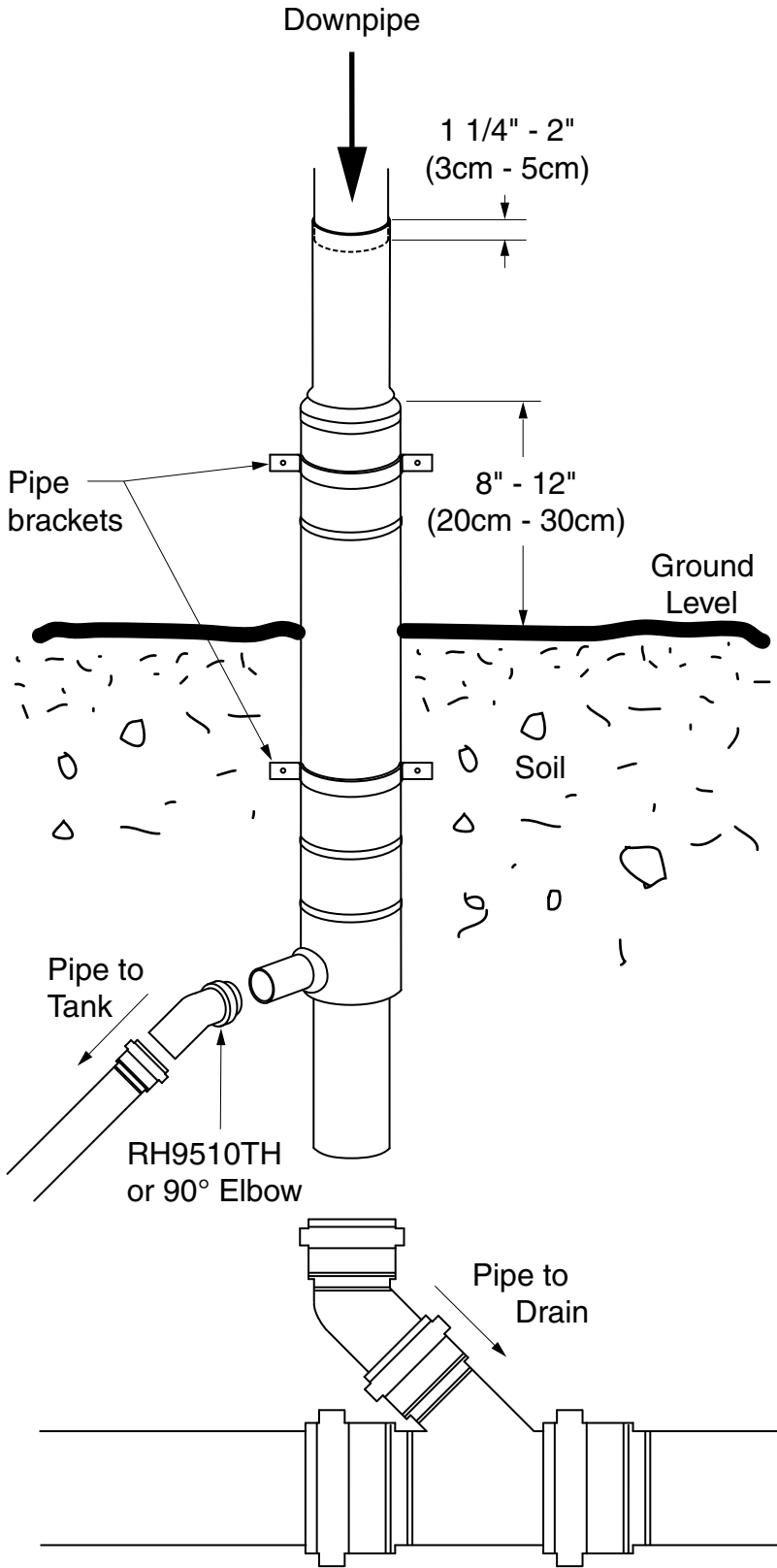

- Identify the desired position that the filter collector will be installed.

- Cut downpipe to allow 1 1/4" - 2" (3 - 5 cm) penetration into upper housing.

- If using downspout converter kit, incorporate length of kit into calculations.

- Install per illustration to left.

- Firmly screw the standpipe housing to the wall with pipe brackets.

- Make the pipe connection for filtered water connection to the tank utilizing the RH9510TH or equal. A 90° elbow or optional 1" flexible hose (with 2" connection) must be installed directly on the 2" outlet to assure proper filtration.

- The standpipe filter can now be backfilled with sand as required.

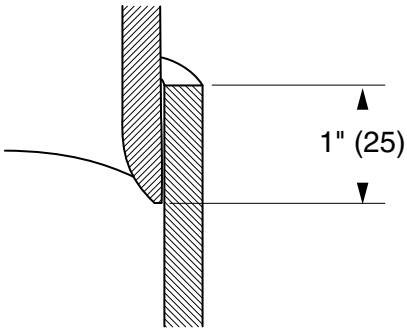

- When correctly installed, the upper downpipe ideally penetrates 1" to 1 1/2" into the filter cap and the lower downpipe penetrates 1" up into the filter body.

- It is important to match the filter size with the correct pipe diameter. The top cap of the filter is designed to be a close fit on the pipe to ensure that water flow is directed over the surface of the filter element.

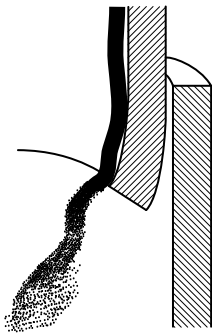

Incorrect

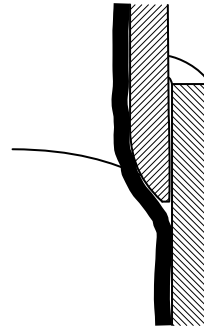

Correct

## Maintenance

- The maintenance required is simple. The filter mesh, to a large extent is self cleaning. However, over a period of time, depending on the roofing material and locality, a thin coating may form on the filter element. This has little effect on the water flow, but it is recommended that the filter element be cleaned with a strong jet of water or simply washed in a dishwasher.

- To take out the filter, slide the upper housing up approximately 8" (205) and lift out the filter element from the lower housing. The filter element can now be cleaned.

- If the filter element is removed, the unit works as a simple collector without filtering. NOTE: Debris will be collected in the storage tank.

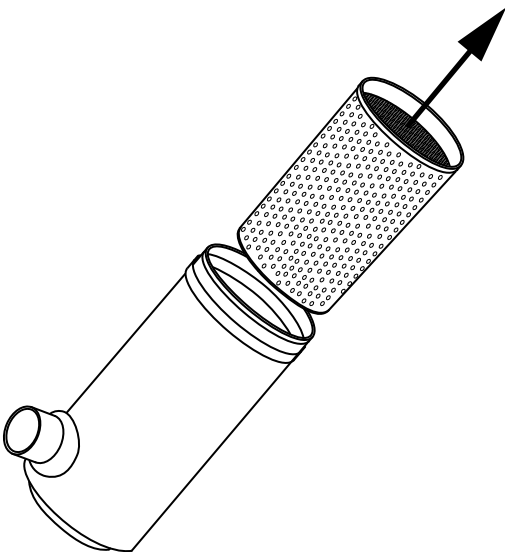



## Damage in transit

Products are carefully checked before shipping, but the risk of damage during transport cannot be guaranteed.

- Check the goods for content and damage on receipt.
- Any damage is the responsibility of the carrier, register any claim with them immediately.
- Contact your supplier before returning any goods.



**JAY R. SMITH MFG. CO.**<sup>®</sup>  
DIVISION OF SMITH INDUSTRIES, INC.  
POST OFFICE BOX 3237  
MONTGOMERY, ALABAMA 36109-0237 (USA)  
TEL: 334-277-8520 FAX: 334-272-7396 [www.jrsmith.com](http://www.jrsmith.com)



MEMBER OF:

