

B



JAY R. SMITH MFG. CO.
 DIVISION OF SMITH INDUSTRIES, INC.
 POST OFFICE BOX 3237
 MONTGOMERY, ALABAMA 36109-0237 (USA)
 TEL: 334-277-8520 FAX: 334-272-7396 www.jrsmith.com



MEMBER OF:

LOCATION

FormIt® DRAIN INSTALLATION DEVICE FOR 12" SQUARE ENAMELED FLOOR SINK SERIES

FUNCTION: The Jay R. Smith Mfg. Co.® FormIt® Drain Installation Device is designed to stabilize the drain and provide adjustment during the installation process and allows final connection of outlet piping to drain after the concrete pour.

DRAWING NUMBER
s3039-DID

SIZE
A

SCALE:
NONE

DATE:
8-28-08

APPROVED BY:
BW

CHECKED BY:
BW

DRAWN BY:
RN

3039-DID

WE CAN ASSUME NO RESPONSIBILITY FOR USE OF SUPERSEDED OR VOID DATA

DIMENSIONS ARE SUBJECT TO MANUFACTURERS TOLERANCE AND CHANGE WITHOUT NOTICE

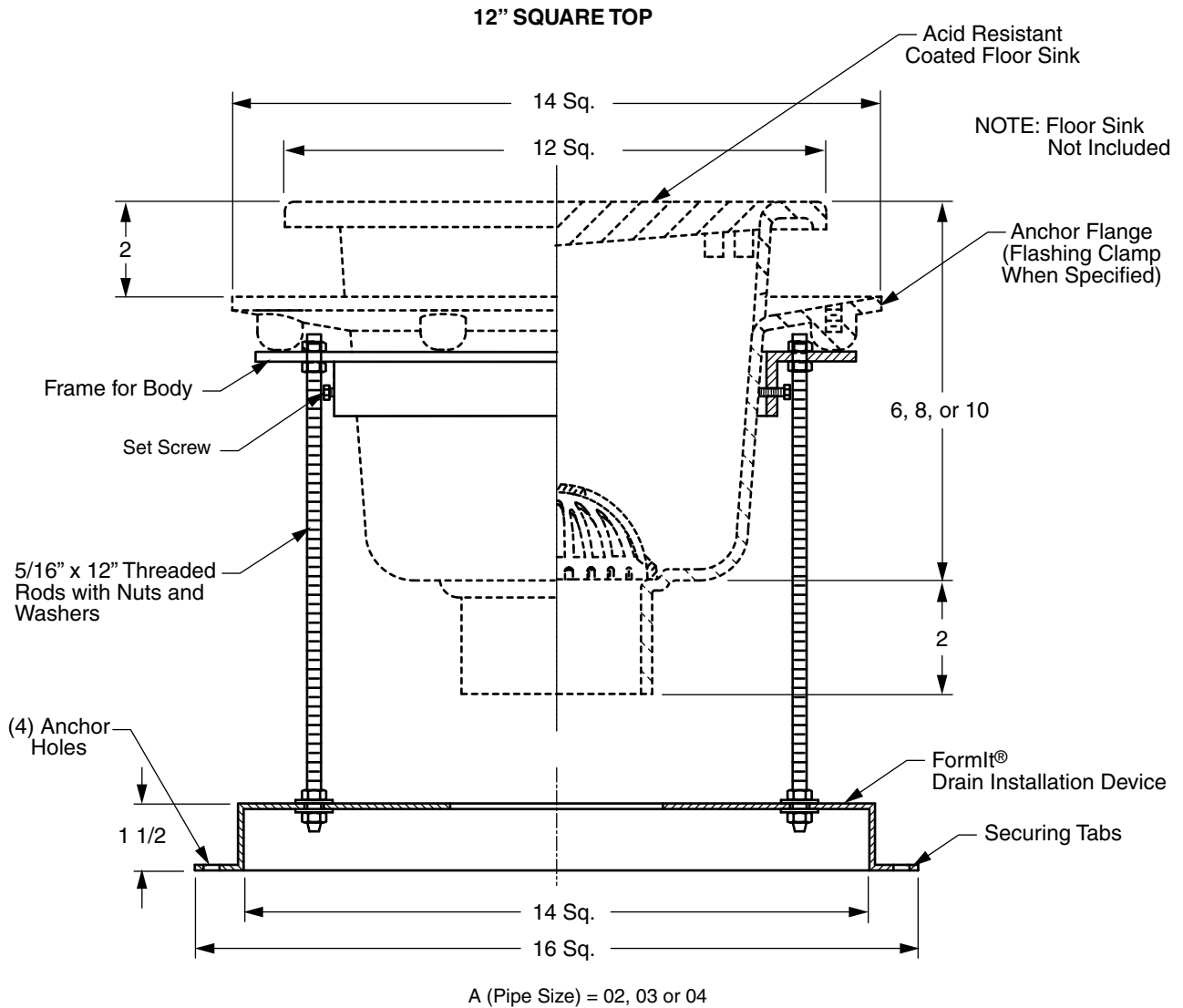

REGULARLY FURNISHED:

FormIt® Drain Installation Device for 12" Square Enameled Floor Sink Series.

B	7-7-10	Revised™ to @	RN	BW	WEIGHT POUNDS	VOLUME CUBIC FEET	FIGURE NUMBER
A	05/14/09	Added Function	JJ	BW			
REV.	DATE	DESCRIPTION	BY	CKD. BY	3039-DID		