

FIGURE NUMBER	<b>9870-477-MADA</b>	DRAWN BY: EMB	CHECKED BY: Pace	APPROVED BY: Pace	DATE: 7-11-96	SCALE: NONE	SIZE <b>A</b>	DRAWING NUMBER a9870-477-MADA	D
---------------	----------------------	------------------	---------------------	----------------------	------------------	----------------	------------------	----------------------------------	---

DIMENSIONS ARE SUBJECT TO MANUFACTURERS TOLERANCE AND CHANGE WITHOUT NOTICE

WE CAN ASSUME NO RESPONSIBILITY FOR USE OF SUPERSEDED OR VOID DATA

# 9870-477-MADA GRATE SPECIFICATION SHEET

Extra Heavy Duty, DIN 19580 Class E - 135,000 lbs - 2,788 psi  
for Commercial Solid Tire Traffic Patterns, Forklifts and Impacts from Steel Struts or Metal Wheels

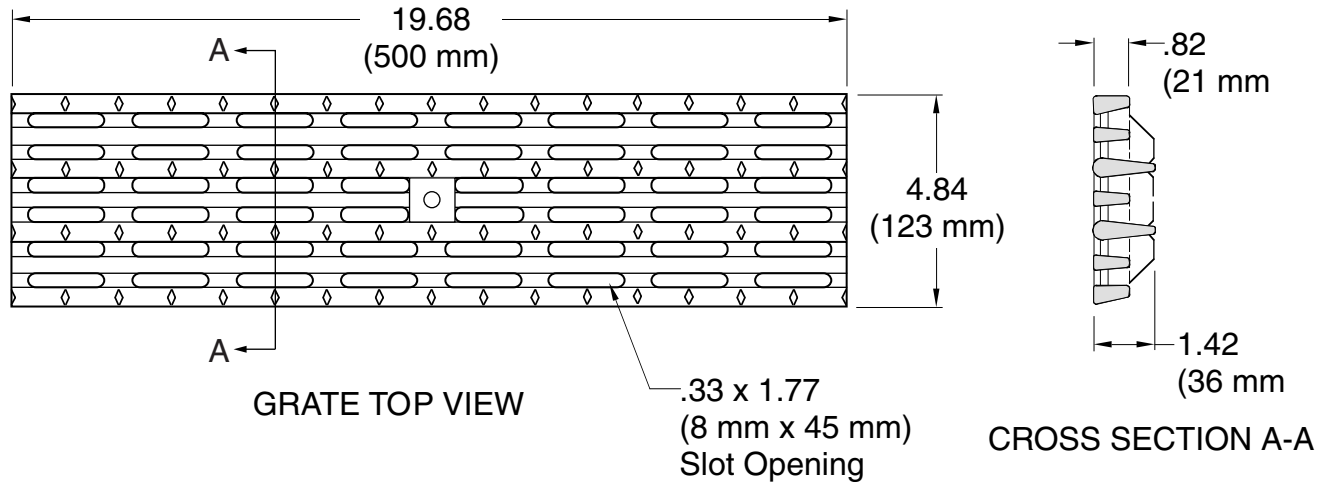

**REGULARLY FURNISHED:**  
Black Duco Coated 1/2 Meter Ductile  
Iron ADA Grate.  
28.50 SQ IN Open Area

**VARIATIONS:**

- Quicklock Locking Device
- 0811LD 5/16-18 x 2" Bolt and locking bar
- 0810LD 5/16-18 x 3 1/4" Bolt and locking bar

**\*NOTE:** 9870-477-MADA Grate is suitable for Heel-Proof Applications.

**NOTE:** Dimensions shown in parentheses are in millimeters.



**SMITH® JAY R. SMITH MFG. CO.®**  
DIVISION OF SMITH INDUSTRIES, INC.  
POST OFFICE BOX 3237  
MONTGOMERY, ALABAMA 36109-0237 (USA)  
TEL: 334-277-8520 FAX: 334-272-7396 www.jrsmith.com



MEMBER OF:

REV.	DATE	DESCRIPTION	BY	CKD. BY
D	10/19/10	Added Variations	RN	MD
C	03/18/10	Added Heel-Proof Note	JJ	PJ
B	9-22-04	Revised Drawing Format	TBW	PJ
A	8-8-96	Added mm Dim's	EMB	PJ