

FIGURE NUMBER	9870-494-PADAG	DRAWN BY:	JJ	CHECKED BY:	PJ	APPROVED BY:	PJ	DATE:	03/24/05	SCALE:	NONE	SIZE	A	DRAWING NUMBER	a9870-494-PADAG
---------------	-----------------------	-----------	----	-------------	----	--------------	----	-------	----------	--------	------	------	---	----------------	-----------------

DIMENSIONS ARE SUBJECT TO MANUFACTURERS TOLERANCE AND CHANGE WITHOUT NOTICE

WE CAN ASSUME NO RESPONSIBILITY FOR USE OF SUPERSEDED OR VOID DATA

9870-494-PADAG GRATE SPECIFICATION SHEET

Light Duty, DIN 19580 Class A - 3,500 lbs - 70 psi
For pedestrian, wheel chair and bicycle traffic

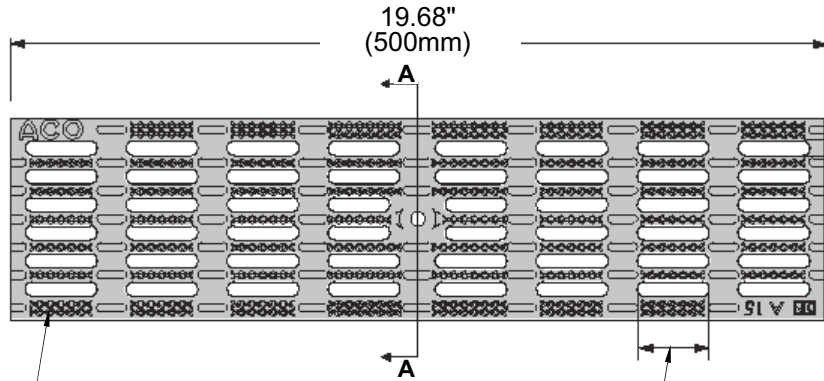

Raised anti-slip surface

GRATE TOP VIEW

.34" (8.5 mm) x 1.74" (44 mm)
Slot Opening

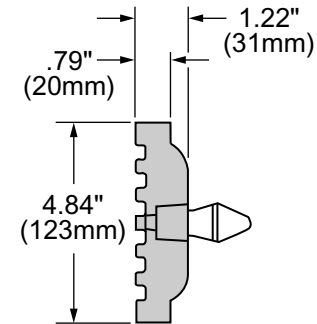

CROSS SECTION A-A



REGULARLY FURNISHED:
 Gray Molded Polypropylene 1/2 Meter
 ADA Compliant Grate with Quick-Lock.

OPEN AREA: 28.00 SQ. IN.

NOTE: Dimensions in parentheses are Metric.

SMITH® JAY R. SMITH MFG. CO.®
 DIVISION OF SMITH INDUSTRIES, INC.
 POST OFFICE BOX 3237
 MONTGOMERY, ALABAMA 36109-0237 (USA)
 TEL: 334-277-8520 FAX: 334-272-7396 www.jrsmith.com



MEMBER OF:

REV.	DATE	DESCRIPTION	BY	CKD. BY